

WTL Catalogue - Aldinet

1. Index.....	1
2. Catalogue 2022.....	2

Aldinet

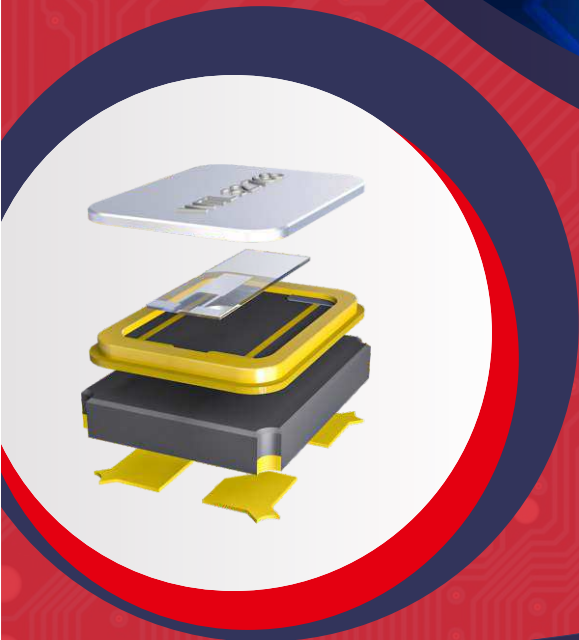

 **WTL**®

*Quartz Crystal
Always WTL*

Edition 4



Aldinet



WTL INTERNATIONAL LIMITED

As an expert for frequency control products, those products may be not so spectacular, but they are closely related to our lives. WTL connects the people and ideas of the world together, returns the world by our dynamic and innovative spirit in the win-win to long rhythm.

Welcome to WTL.







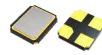
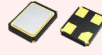
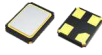
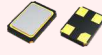
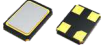

深圳市维拓精电科技有限公司

作为频率控制产品的专家，我们的产品并不那么引人注目，但它与我们的生活却息息相关。维拓将来自世界各地的人和思维融合在一起，秉承着“共赢之源，维拓百年”经营理念，以我们的激进向上，科技创新来回报您与整个世界。



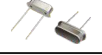





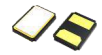

维拓，真诚欢迎您！

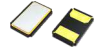

















Quartz Crystal

Page	Series	Dimension(mm)	Frequency	PAD	Picture
1	TX9	1.2 x 1.0 x 0.33	32MHz-96MHz	4	
2	TX8	1.6 x 1.2 x 0.35	20MHz-66MHz	4	
3	TX1	2.0 x 1.6 x 0.5	16MHz-96MHz	4	
4	TX2	2.5 x 2.0 x 0.55	12MHz-54MHz	4	
5	TX3	3.2 x 2.5 x 0.7	8MHz-104MHz	4	
6	TX5	5.0 x 3.2 x 0.9	8MHz-100MHz	4	
7	TX7	7.0 x 5.0 x 1.1	6MHz-110MHz	4	
8	TG5	5.0 x 3.2 x 1.2	8MHz-80MHz	2	
9	WX6	HC-49S 11.05 x 4.7 x 3.68	3.2MHz-100MHz	2	
10	WS6	HC-49SS 11.05 x 4.7 x 2.0/2.5/3.0	3.2MHz-100MHz	2	
11	WS7	HC-49SS SMD 12.7x 4.8 x 2.0/2.5/3.0	3.2MHz-100MHz	2	
12	WX7	HC-49S SMD 12.7 x 4.8 x 3.8	3.2MHz-100MHz	2	









Tuning fork Crystal

Page	Series	Dimension(mm)	Frequency	PAD	Picture
13	TS7	1.2 x 1.0 x 0.5	32.768kHz	2	
14	TS8	1.6 x 1.0 x 0.5	32.768kHz	2	
15	TS9	2.0 x 1.2 x 0.6	32.768kHz	2	
16	WX1	3.2 x 1.5 x 0.75	32.768kHz	2	
17	WX3	3.8 x 8.0 x 2.5	30kHz-350kHz	4	
18	WX4	6.9 x 1.4 x 1.3	32.768kHz	4	
19	WX2	Φ2 x 6	30kHz-350kHz	2	
20	WT8	Φ3 x 8	30kHz-350kHz	2	
21	WA4	Φ2 x 6/SMD	32.768kHz	2	
22	WX8	Φ2 x 6 /SMD	30kHz-350kHz	2	









Crystal Oscillator(CMOS)

Page	Series	Dimension(mm)	Frequency	PAD	Picture
23	TK2	2.5 x 2.0 x 0.81	32.768kHz	4	
24	TK3	3.2 x 2.5 x 0.95	32.768kHz	4	
25	TK4	2.5 x 2.0 x 0.81	32.768kHz <small>Low Current Consumption</small>	4	
26	TK5	3.2 x 2.5 x 0.95	32.768kHz <small>Low Current Consumption</small>	4	
27	TC1	2.05 x 1.65 x 0.75	1.5MHz-50MHz	4	
28	TC2	2.5 x 2.0 x 0.81	1.25MHz-125MHz	4	
29	TC3	3.2 x 2.5 x 0.95	1.25MHz-125MHz	4	
30	TC5	5.0 x 3.2 x 1.2	13.7kHz-160MHz	4	
31	TC7	7.0 x 5.0 x 1.3	13.7kHz-166MHz	4	
32	TU2	2.5 x 2.0 x 0.81	1MHz-50MHz <small>Ultra Low Power</small>	4	
33	TU3	3.2 x 2.5 x 0.95	1MHz-50MHz <small>Ultra Low Power</small>	4	
34	TW2	2.5 x 2.0 x 0.81	1.25MHz-100MHz <small>Extended Operating temperatureRange</small>	4	
35	TW3	3.2 x 2.5 x 0.95	1.25MHz-100MHz <small>Extended Operating temperatureRange</small>	4	
36	TN2	2.5 x 2.0 x 0.81	20MHz-60MHz <small>Ultra Low Noise</small>	4	
37	TN3	3.2 x 2.5 x 0.95	20MHz-60MHz <small>Ultra Low Noise</small>	4	
38	LO1	20.8 x 12.46 x 5	0.25MHz-180MHz	4	
39	LO2	12.46 x 12.46 x 5	0.25MHz-180MHz	4	

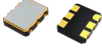

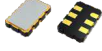







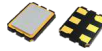

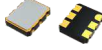
FASTXO Crystal Oscillator(CMOS)

Page	Series	Dimension(mm)	Frequency	PAD	Picture
40	TB1	2.05 x 1.65 x 0.75	1MHz-200MHz	4	
41	TB2	2.5 x 2.0 x 0.81	1MHz-200MHz	4	
42	TB3	3.2 x 2.5 x 0.95	1MHz-200MHz	4	
43	TB5	5.0 x 3.2 x 1.2	1MHz-200MHz	4	
44	TB7	7.0 x 5.0 x 1.3	1MHz-200MHz	4	
45	TL2	3.2 x 2.5 x 0.90	10MHz-250MHz <small>Low Phase Jitter</small>	6	
46	TL4	5.0 x 3.2 x 1.25	10MHz-250MHz <small>Low Phase Jitter</small>	6	
47	TL6	7.0 x 5.0 x 1.45	10MHz-250MHz <small>Low Phase Jitter</small>	6	





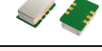

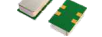



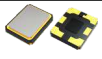

Crystal Oscillator(LVPECL/LVDS/HCSL/CML)

Page	Series	Dimension(mm)	Frequency	PAD	Picture
48	TL3	3.2 x 2.5 x 0.90	10MHz-1500MHz	6	
49	TL5	5.0 x 3.2 x 1.25	10MHz-1500MHz	6	
50	TL7	7.0 x 5.0 x 1.45	10MHz-1500MHz	6	
51	TP3	3.2 x 2.5 x 0.90	10MHz-250MHz Low Phase Jiter	6	
52	TP5	5.0 x 3.2 x 1.25	10MHz-320MHz Low Phase Jiter	6	
53	TP7	7.0 x 5.0 x 1.45	10MHz-320MHz Low Phase Jiter	6	
54	TN7	7.0 x 5.0 x 1.45	70MHz-170MHz Ultra Low Phase Jiter	6	
55	TQ7	7.0 x 5.0 x 1.45	25MHz-75MHz HCSL	6	







VCXO

Page	Series	Dimension(mm)	Frequency	PAD	Picture
56	PV3	3.2 x 2.5 x 0.9	10MHz-250MHz	6	
57	PV5	5.0 x 3.2 x 1.25	10MHz-250MHz	6	
58	PV7	7.0 x 5.0 x 1.75	10MHz-250MHz	6	
59	PL3	3.2 x 2.5 x 0.9	10MHz-1500MHz Differenntial Output	6	
60	PL5	5.0 x 3.2 x 1.25	10MHz-1500MHz Differenntial Output	6	
61	PL7	7.0 x 5.0 x 1.75	10MHz-1500MHz Differenntial Output	6	
62	CL5	5.0 x 3.2 x 1.25	30MHz-250MHz Low Phase Jiter	6	
63	CL7	7.0 x 5.0 x 1.75	1.5MHz-200MHz Low Phase Jiter	6	
64	CV5	5.0 x 3.2 x 1.25	1.5MHz-170MHz Extended Operating emperatureRange	6	
65	CV7	7.0 x 5.0 x 1.75	1.5MHz-170MHz Extended Operating emperatureRange	6	
66	CV8	14.2 x 9.3 x 5.4	30MHz-250MHz	6	
67	LV1	20.3 x 12.6 x 5.0 12.6 x 12.6 x 5.0	1MHz-80MHz	4	
68	LV2	13.9 x 9.1 x 3.6	50MHz-125MHz	4	

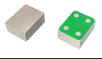
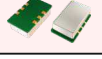

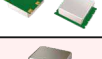
TCXO/VCTCXO

Page	Series	Dimension(mm)	Frequency	PAD	Picture
69	VC1	2.0 x 1.6 x 0.7	10MHz-52MHz	4/6	
70	VC2	2.5 x 2.0 x 0.7	10MHz-52MHz	4	
71	VC3	3.2 x 2.5 x 0.9	10MHz-52MHz	4	
72	VC5	5.0 x 3.2 x 1.1	10MHz-52MHz	4	
73	VC7	7.0 x 5.0 x 1.9	5MHz-52MHz	4	
74	VC8	14.3 x 8.7 x 4.9	5MHz-40MHz	6	
75	VP3	3.2 x 2.5 x 1.6	10MHz-1500MHz High Frequency Temperature Compensated	6	
76	VW5	5.0 x 3.2 x 1.55	10MHz-52MHz High Precision	4	
77	VA7	7.0 x 5.0 x 1.9	5MHz-52MHz High Precision	4	
78	VS7	7.0 x 5.0 x 1.9	5MHz-52MHz Stratum 3	4	
79	VT7	7.0 x 5.0 x 1.9	10MHz-52MHz High Precision and High Temperature	4	
80	VF2	20.4 x 12.8 x 7.8	10MHz-52MHz	4	
81	WT1	18.5x12 to 91x56	1MHz-1500MHz	4/5	

OCXO

Page	Series	Dimension(mm)	Frequency	PAD	Picture
82	OC9	9.7 x 7.5 x 4.1	10MHz-40MHz	4	
83	OC8	14.3 x 9.3 x 6.5	10MHz-40MHz	6	
84	OCH	20.3 x 12.7 x 11.0	5MHz-40MHz	4	
85	OCW	20.6 x 20.6 x 11.0	5MHz-40MHz	5	
86	OSD	25.4 x 22.1 x 11.0	5MHz-40MHz	7	
87	OLH	25.4 x 25.4 x 12.7	5MHz-40MHz	5	
88	OCN	25.4 x 25.4 x 12.7	10MHz-40MHz Low Phase Noise, Low G-Sensitivity	5	
89	OSH	36.3 x 27.2 x 12.7	5MHz-40MHz	5	
90	OCD	36.3 x 27.2 x 18.7	10MHz DOCXO	5	

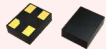
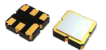
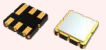
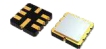
SAW Resonator

Page	Series	Dimension(mm)	Frequency	PAD	Picture
91	SR1	2.0 x 1.6 x 1.0	154MHz-1000MHz	4	
92	SR3	3.0 x 3.0 x 1.25	154MHz-1000MHz	6	
93	SR4	3.8 x 3.8 x 1.5	154MHz-1000MHz	6	
94	SR5	5.0 x 5.0 x 1.5	154MHz-1000MHz	8	
95	SR6	5.0 x 3.5 x 1.4	154MHz-1000MHz	4	

SAW Filter

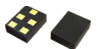
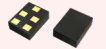
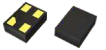
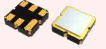
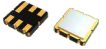
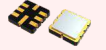
Page	Series	Dimension(mm)	Frequency	PAD	Picture
96	SF0	1.1 x 0.9 x 0.5	800MHz-2605MHz	5	
97	SF1	1.4 x 1.1 x 0.6	800MHz-2605MHz	5	
98	SF2	2.0 x 1.5 x 0.6	800MHz-2605MHz	4	
99	SF3	3.0 x 3.0 x 1.25	300MHz-2605MHz	6	
100	SF4	3.8 x 3.8 x 1.5	100MHz-1000MHz	6	
101	SF5	5.0 x 5.0 x 1.5	100MHz-1000MHz	8	

SMD Seam Sealed Crystals 1.2×1.0×0.33 mm

Feature

- Size 1.2 × 1.0, ultra miniature and lightweight SMD crystal with a low profile of 0.33mm
- Seam with vacuum Sealed for Ultra-small size
- High precision and high reliability
- Automatic mounting is possible
- Reflow is possible
- RoHS Compliant / Pb Free

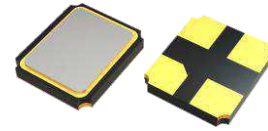

Electrical Specifications

Item	Specifications	
Frequency Range(MHz)	32~40	40~96
Mode	AT/Fundamental	
Load Capacitance (CL)	8pF, 10pF, 12pF or Specify	
Frequency Tolerance(at 25°C)	±10ppm~±30ppm or specify	
Operating emperature Range	-20~+70°C or Specify	
Frequency Stability Over Operating emperature Range	±10ppm ~ ±30ppm or specify	
Equivalent Series Resistance (ESR) max.	150Ω	100Ω
Storage Temperature Range	-55~+125°C	
Shunt Capacitance(C ₀)	3pF Max	
Drive Level (Typical)	50μW max	
Aging @25°C 1st Year (Max)	±2 ppm, ±5ppm	

Dimension(mm)

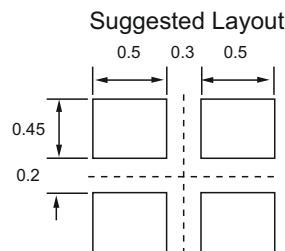
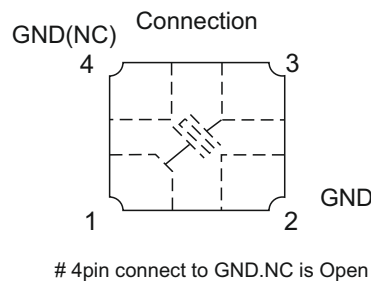
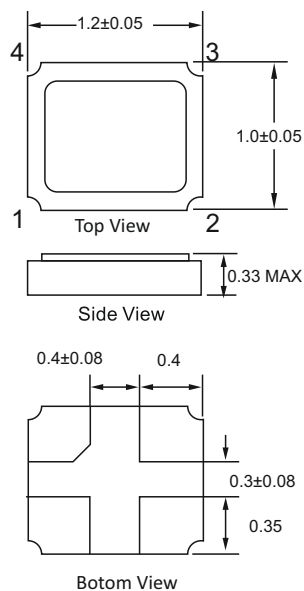

SMD Seam Sealed Crystals 1.6×1.2×0.35 mm

Feature

- Size 1.6 × 1.2 , Ultra thin , thickness 0.35mm
- High precision and high frequency stability
- Designed for automatic mounting and reflow soldering
- RoHS Compliant /Pb Free

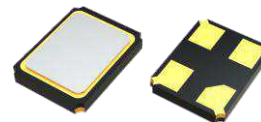

Electrical Specifications

Item	Specifications		
Frequency Range(MHz)	20~24	24~30	30~66
Mode	AT/Fundamental		
Load Capacitance (CL)	8pF, 10pF, 12pF or Specify		
Frequency Tolerance(at 25°C)	±10ppm~±30ppm or specify		
Operating emperature Range	-20~+70°C or Specify		
Frequency Stability Over Operating emperature Range	±10ppm ~ ±30ppm or specify		
Equivalent Series Resistance (ESR) max.	150Ω	100Ω	80Ω
Storage Temperature Range	-55~+125°C		
Shunt Capacitance(C ₀)	3pF Max		
Drive Level (Typical)	1 ~ 200μW (50μW typical)		
Aging @25 °C 1st Year (Max)	±3 ppm/year		

Dimension(mm)

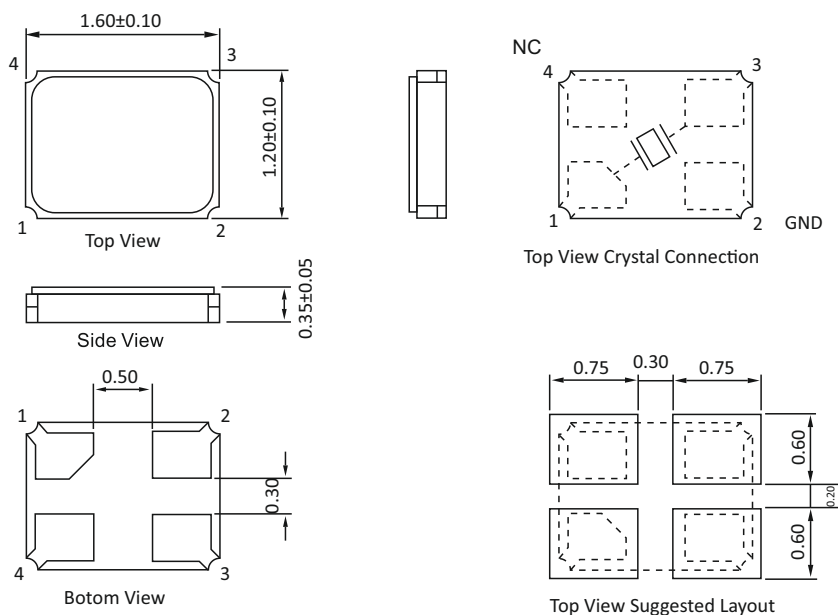

SMD Seam Sealed Crystals 2.0×1.6×0.5 mm

Feature

- Size 2.0 × 1.6 , Ultra thin , thickness 0.5mm
- High precision and high frequency stability
- Excellent heat resistance and environmental characteristics
- Designed for automatic mounting and reflow soldering
- RoHS Compliant / Pb Free

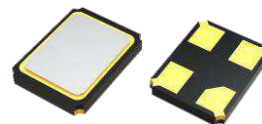

Electrical Specifications

Item	Specifications		
Frequency Range(MHz)	16~19.2	19.2~30	30~96
Mode	AT/Fundamental		
Load Capacitance (CL)	8pF, 10pF, 12pF or Specify		
Frequency Tolerance(at 25°C)	±10ppm ~ ±30ppm or specify		
Operating emperature Range	-20~+70°C or Specify		
Frequency Stability Over Operating emperature Range	±10ppm ~ ±30ppm or specify		
Equivalent Series Resistance (ESR) max.	200Ω	100Ω	80Ω
Storage Temperature Range	-55~+125°C		
Shunt Capacitance(C ₀)	3pF Max		
Drive Level (Typical)	1 ~ 200μW (50μW typical)		
Aging @25°C 1st Year (Max)	±3 ppm/year		

Dimension(mm)

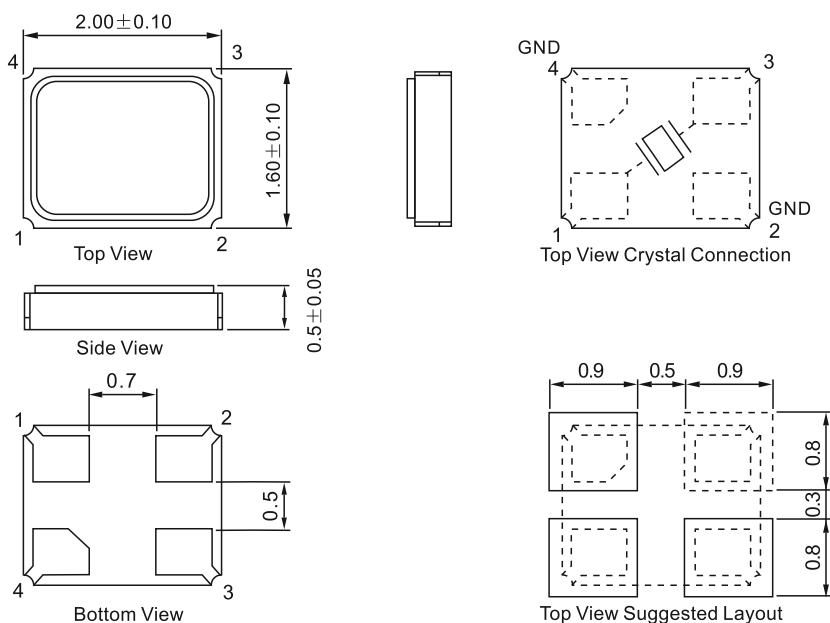

SMD Seam Sealed Crystals 2.5×2.0×0.55 mm

Feature

- Size 2.5 × 2.0 , Ultra thin , thickness 0.55mm
- High precision and high frequency stability
- Excellent heat resistance and environmental characteristics
- Designed for automatic mounting and reflow soldering
- RoHS Compliant / Pb Free

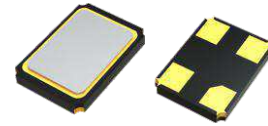

Electrical Specifications

Item	Specifications	
Frequency Range(MHz)	12~24	24~54
Mode	AT/Fundamental	
Load Capacitance (CL)	8pF, 10pF, 12pF or Specify	
Frequency Tolerance(at 25°C)	±10ppm ~ ±30ppm or specify	
Operating emperature Range	-20~+70°C or Specify	
Frequency Stability Over Operating emperature Range	±10ppm ~ ±50ppm or specify	
Equivalent Series Resistance (ESR) max.	80Ω	60Ω
Storage Temperature Range	-55~+125°C	
Shunt Capacitance(C ₀)	3pF Max	
Drive Level (Typical)	1 ~100 μW (10μW typical)	
Aging @ 25°C 1st Year (Max)	±3 ppm/year	

Dimension(mm)

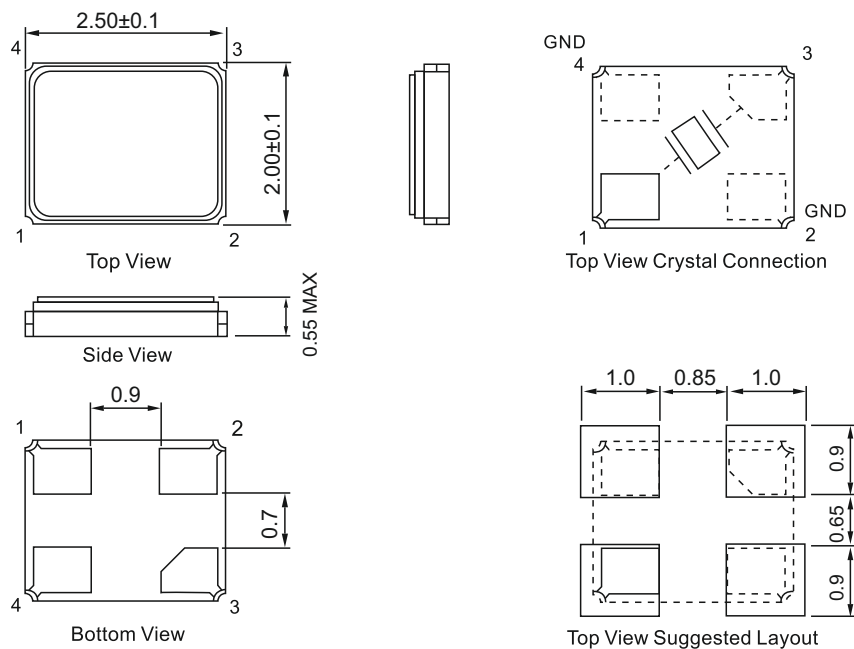

SMD Seam Sealed Crystals 3.2×2.5×0.7 mm

Feature

- Size 3.2×2.5, Ultra thin , thickness 0.7mm
- High precision and high frequency stability
- Excellent heat resistance and environmental characteristics
- Designed for automatic mounting and reflow soldering
- RoHS Compliant /Pb Free

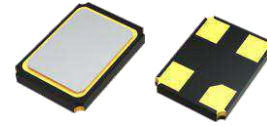

Electrical Specifications

Item	Specifications		
Frequency Range(MHz)	8~10	10~24	24~104
Mode	AT/Fundamental		
Load Capacitance (CL)	8pF, 9pF, 10pF, 12pF, 18pF, 20pF, or Specify		
Frequency Tolerance(at 25°C)	±10ppm ~ ±30ppm or specify		
Operating emperature Range	-20~+70°C or Specify		
Frequency Stability Over Operating emperature Range	±10ppm ~ ±30ppm or specify		
Equivalent Series Resistance (ESR) max.	200Ω	80Ω	60Ω
Storage Temperature Range	-55~+125°C		
Shunt Capacitance(C 0)	3pF Max		
Drive Level (Typical)	1~ 100 μW (50μW typical)		
Aging @25°C 1st Year (Max)	±3 ppm/year max		

Dimension(mm)

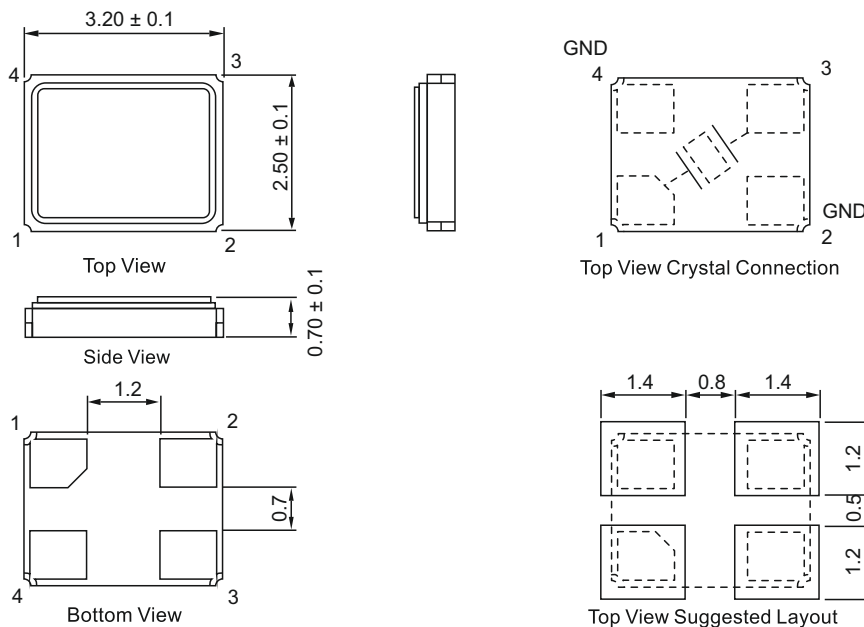

SMD Seam Sealed Crystals 5.0×3.2×0.9 mm

Feature

- Size 5.0×3.2, thickness 0.9mm
- High precision and high frequency stability
- Excellent heat resistance and environmental characteristics
- Designed for automatic mounting and reflow soldering
- RoHS Compliant / Pb Free

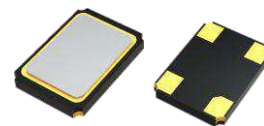

Electrical Specifications

Item	Specifications			
Frequency Range(MHz)	8~12	12~48	40~60	60~100
Mode	AT/Fundamental		AT/3RD	
Load Capacitance (CL)	8pF, 16pF, 20pF, 30pF, or Specify			
Frequency Tolerance(at 25°C)	±10ppm ~ ±30ppm or specify			
Operating emperature Range	-20~+70°C or Specify			
Frequency Stability Over Operating emperature Range	±10ppm ~ ±30ppm or specify			
Equivalent Series Resistance (ESR) max.	60Ω	45Ω	120Ω	80Ω
Storage Temperature Range	-55~+125°C			
Shunt Capacitance(C ₀)	5pF Max			
Drive Level (Typical)	1 ~ 100 μW (10μW typical)			
Aging @25 °C 1st Year (Max)	±3 ppm/year			

Dimension(mm)

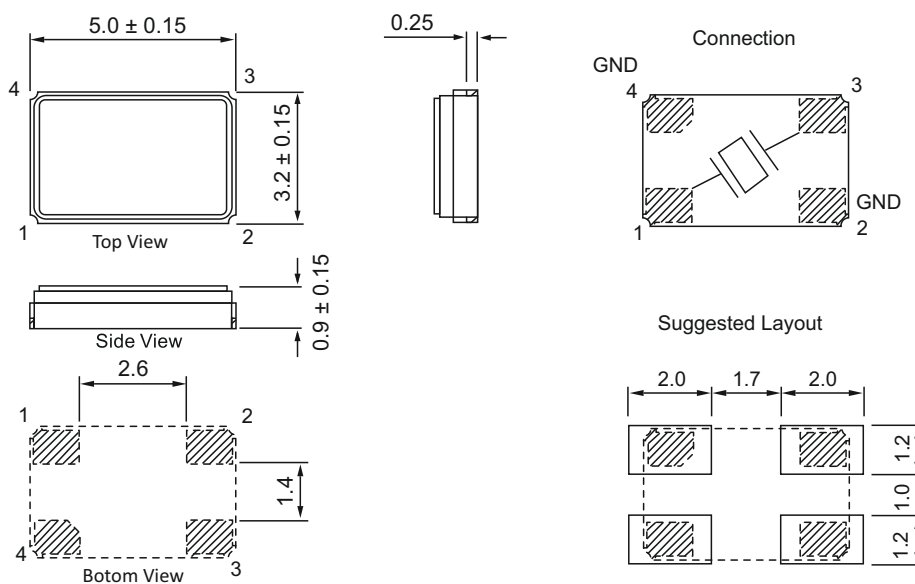

SMD Seam Sealed Crystals 7.0×5.0×1.1 mm

Feature

- SMD type crystal units
- High precision and high frequency stability
- Excellent heat resistance and environmental characteristics
- Designed for automatic mounting and reflow soldering
- RoHS Compliant / Pb Free

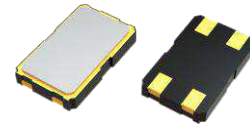

Electrical Specifications

Item	Specifications		
Frequency Range(MHz)	6~8	8~48	32~110
Mode	AT/Fundamental		AT/3RD
Load Capacitance (CL)	8pF, 16pF, 20pF, 30pF, or Specify		
Frequency Tolerance(at 25°C)	±10ppm ~ ±30ppm or specify		
Operating emperature Range	-20~+70°C or Specify		
Frequency Stability Over Operating emperature Range	±10ppm ~ ±30ppm or specify		
Equivalent Series Resistance (ESR) max.	100Ω	60Ω	80Ω
Storage Temperature Range	-55~+125°C		
Shunt Capacitance(C ₀)	5pF Max		
Drive Level (Typical)	1~100 μW		
Aging @ 25°C 1st Year (Max)	±3 ppm/year		

Dimension(mm)

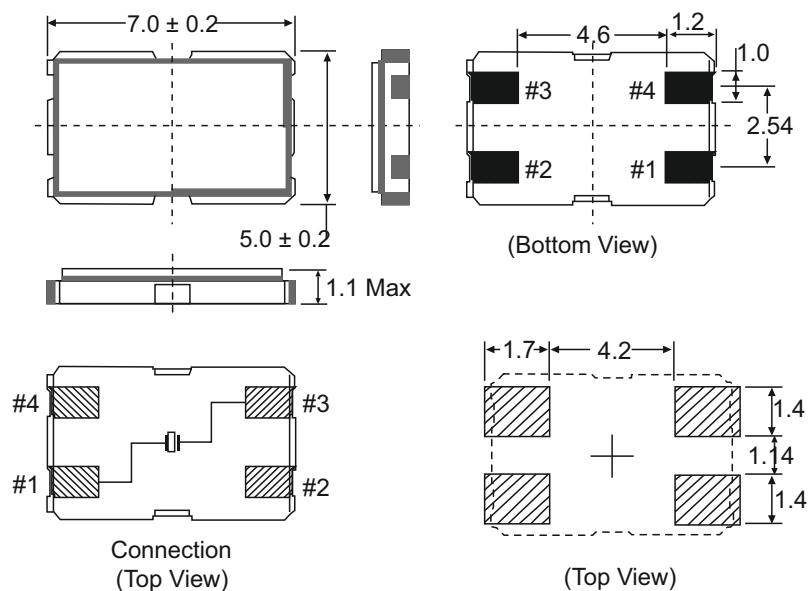

SMD Glass Sealed Ceramic 5.0×3.2×1.2 mm

Feature

- 2 pads SMD glass sealed crystal units
- High reliable environmental performance
- Tight tolerance and stability parts are available
- Designed for automatic mounting and reflow soldering
- Contains Pb in sealing glass exempted by RoHS directive



Electrical Specifications

Item	Specifications		
Frequency Range(MHz)	8~12	12~54	40~80
Mode	AT/Fundamental		AT/3RD
Load Capacitance (CL)	10pF, 20pF, 30pF, 32pF or Specify		
Frequency Tolerance(at 25°C)	±10ppm ~ ±30ppm or specify		
Operating emperature Range	-20~+70°C or Specify		
Frequency Stability Over Operating emperature Range	±10ppm ~ ±30ppm or specify		
Equivalent Series Resistance (ESR) max.	60Ω	40Ω	100Ω
Storage Temperature Range	-55~+125°C		
Shunt Capacitance(C ₀)	5pF Max		
Drive Level (Typical)	1~200μW (100μW typical)		
Aging @25°C 1st Year (Max)	±3 ppm/year		

Dimension(mm)

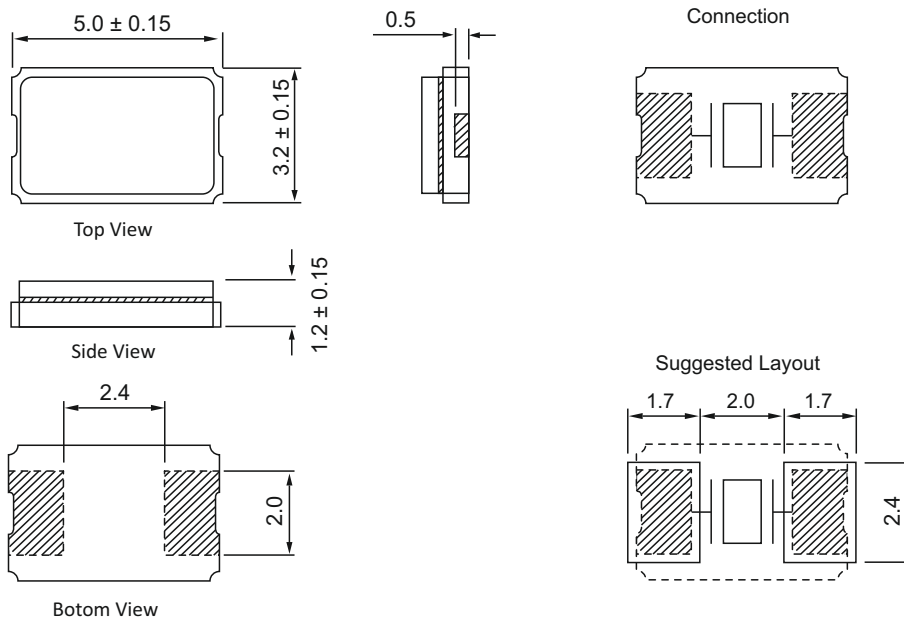

Resistance Welded HC-49S 11.05×4.7×3.68 mm

Feature

- Resistance welded type crystal units
- A great number of standard frequencies
- Higher frequency available and lower equivalent series resistance
- Lower cost and highly mass production capability
- RoHS Compliant / Pb Free

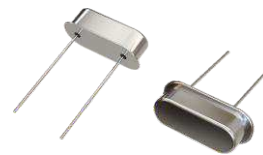

Electrical Specifications

Item	Specifications					
Frequency Range(MHz)	3.2~6	6~8	8~16	16~54	30~50	50~100
Mode	AT/Fundamental			AT/3RD	AT/3RD	
Load Capacitance (CL)	8pF, 10pF, 12pF or Specify					
Frequency Tolerance(at 25°C)	±10ppm ~ ±30ppm or Specify					
Operating emperature Range	-20~+70°C or Specify					
Frequency Stability Over Operating emperature Range	±10ppm ~ ±30ppm or Specify					
Equivalent Series Resistance (ESR) max.	150Ω	60Ω	50Ω	30Ω	80Ω	60Ω
Storage Temperature Range	-55~+125°C					
Shunt Capacitance(C ₀)	7.0 pF Max					
Drive Level (Typical)	1 μW~100 μW (10μW typical)					
Aging @25 °C 1st Year (Max)	±3 ppm/year or ±5 ppm/year					

Dimension(mm)

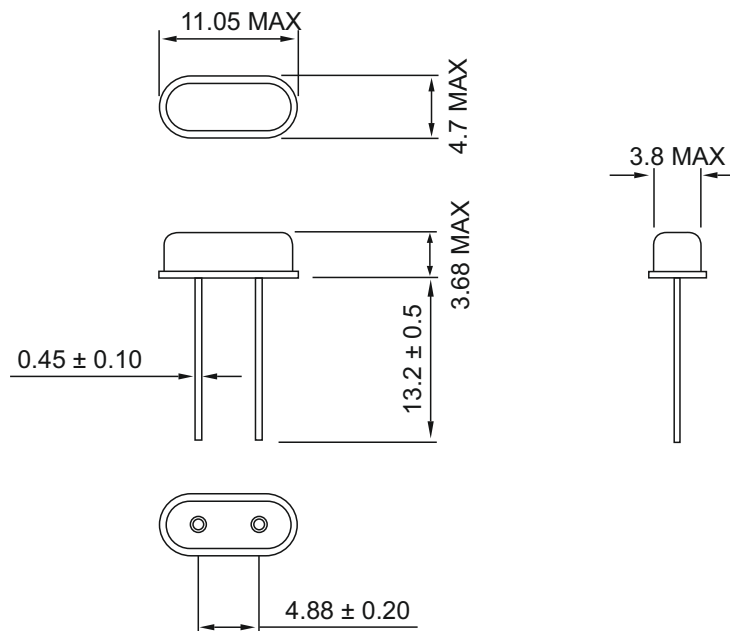

Resistance Welded HC-49SS 11.05×4.7×2.0/2.5/3.0 mm

Feature

- Resistance welded type crystal units, Height: 3.0/2.5/2.0mm
- Higher frequency available and lower equivalent series resistance
- Lower cost and highly mass production capability
- RoHS Compliant / Pb Free

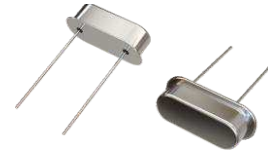

Electrical Specifications

Item	Specifications					
Frequency Range(MHz)	3.2~6	6~8	8~16	16~54	30~50	50~100
Mode	AT/Fundamental			AT/3RD	AT/3RD	
Load Capacitance (CL)	8pF, 10pF, 12pF or Specify					
Frequency Tolerance(at 25°C)	±10ppm ~ ±30ppm or specify					
Operating emperature Range	-20~+70°C or Specify					
Frequency Stability Over Operating emperature Range	±10ppm ~ ±30ppm or specify					
Equivalent Series Resistance (ESR) max.	150Ω	60Ω	50Ω	30Ω	80Ω	60Ω
Storage Temperature Range	-55~+125°C					
Shunt Capacitance(C ₀)	7.0 pF Max					
Drive Level (Typical)	1 μW~100 μW (10μW typical)					
Aging @25 °C 1st Year (Max)	±3 ppm/year or ±5 ppm/year					

Dimension(mm)

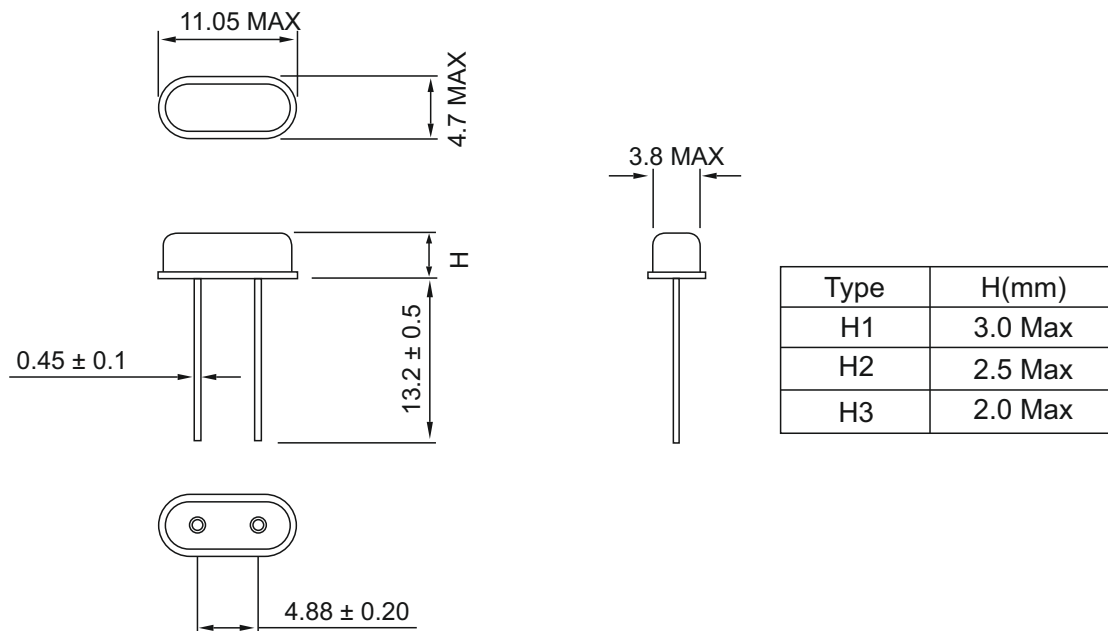

Resistance Welded HC-49SS SMD

12.7×4.8×2.5/2.8/3.0 mm

Feature

- Surface mount type crystal units, Height: 2.5/2.8/3.0 mm
- A great number of standard frequencies
- Higher frequency available and lower equivalent series resistance.
- Lower cost and highly mass production capability.
- RoHS Compliant / Pb Free



Electrical Specifications

Item	Specifications					
Frequency Range(MHz)	3.2~6	6~8	8~16	16~54	30~50	50~100
Mode	AT/Fundamental			AT/3RD	AT/3RD	
Load Capacitance (CL)	8pF, 10pF, 12pF or Specify					
Frequency Tolerance(at 25°C)	±10ppm ~ ±30ppm or specify					
Operating emperature Range	-20~+70°C or Specify					
Frequency Stability Over Operating emperature Range	±10ppm ~ ±30ppm or specify					
Equivalent Series Resistance (ESR) max.	150Ω	60Ω	50Ω	30Ω	80Ω	60Ω
Storage Temperature Range	-55~+125°C					
Shunt Capacitance(C ₀)	7.0 pF Max					
Drive Level (Typical)	1 μW~500 μW (100μW typical)					
Aging @25 °C 1st Year (Max)	±3 ppm/year or ±5 ppm/year					

Dimension(mm)

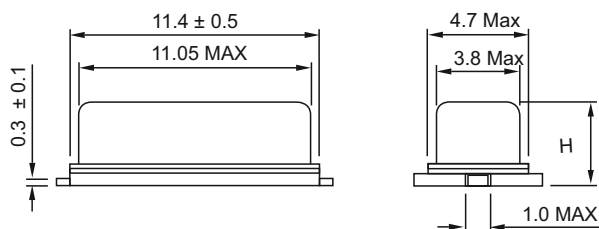

Type	H(mm)
H1	3.0 Max
H2	2.8 Max
H3	2.5 Max

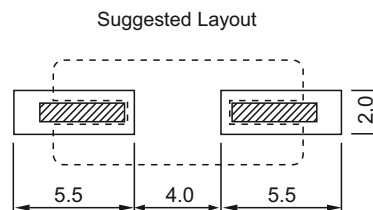
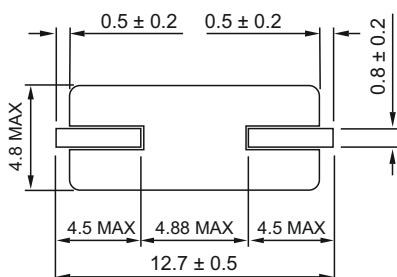

Resistance Welded HC-49SMD

12.7×4.8×3.8 mm

Feature

- Surface mount type crystal units.
- A great number of standard frequencies.
- Higher frequency available and lower equivalent series resistance.
- Lower cost and highly mass production capability.
- RoHS Compliant / Pb Free



Electrical Specifications

Item	Specifications					
	3.2~6	6~8	8~16	16~54	30~50	50~100
Frequency Range(MHz)	3.2~6	6~8	8~16	16~54	30~50	50~100
Mode	AT/Fundamental			AT/3RD	AT/3RD	
Load Capacitance (CL)	8pF, 10pF, 12pF or Specify					
Frequency Tolerance(at 25°C)	±10ppm ~ ±30ppm or specify					
Operating emperature Range	-20~+70°C or Specify					
Frequency Stability Over Operating emperature Range	±10ppm ~ ±30ppm or specify					
Equivalent Series Resistance (ESR) max.	150Ω	60Ω	50Ω	30Ω	80Ω	60Ω
Storage Temperature Range	-55~+125°C					
Shunt Capacitance(C ₀)	7.0 pF Max					
Drive Level (Typical)	1 μW~500 μW (100μW typical)					
Aging @25 °C 1st Year (Max)	±3 ppm/year or ±5 ppm/year					

Dimension(mm)

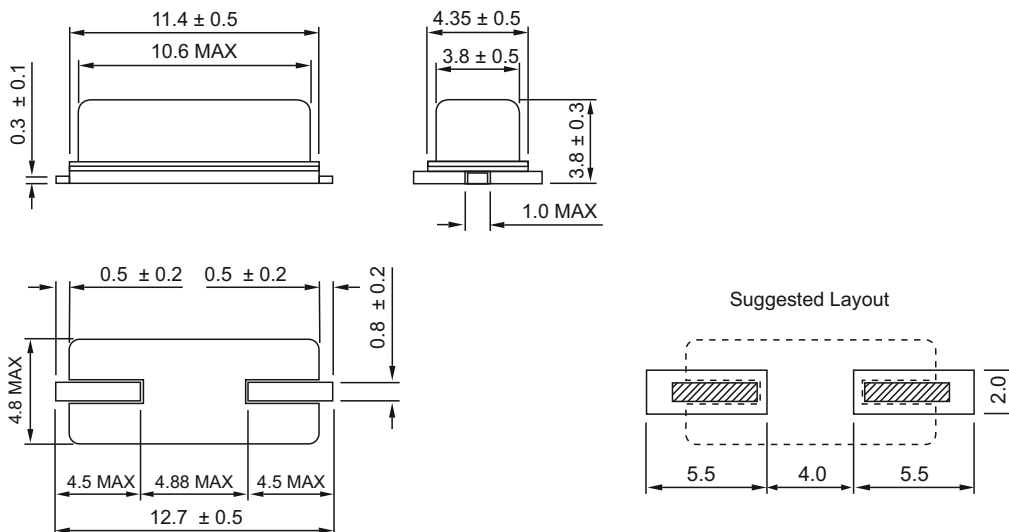

1.2 x 1.0 x 0.5 mm SMD Package

Feature

- Ultra small size 1.2x1.0x0.5 mm
- High reliability environmental performance
- High frequency stability and high precision
- Designed for automatic mounting and reflow soldering
- RoHS Compliant / Pb Free

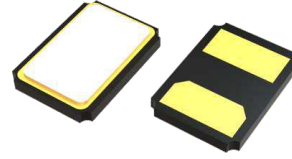

Electrical Specifications

Item	Specifications
Frequency	32.768kHz
Load Capacitance (CL)	6pF, 7pF, 9pF , 12.5pF
Frequency Tolerance(at 25°C)	±20ppm
Operating emperature Range	-40~+85°C
Turnover Temperature	25 ± 5°C
Frequency Temperature Curve	$(-0.036 \pm 10\%) \times 10^6 / ^\circ\text{C}^2$
Equivalent Series Resistance (ESR) max.	90kΩ
Drive Level (Typical)	0.1μW
Drive Level(Max)	0.3μW
Shunt Capacitance(C ₀)	1.4pF Typ.
Insulation esistance	More than 500Mohms at DC100V
Storage Temperature Range	-55°C~+125°C
Aging @25°C 1st Year (Max)	±3ppm/year

DIMENSION(mm)

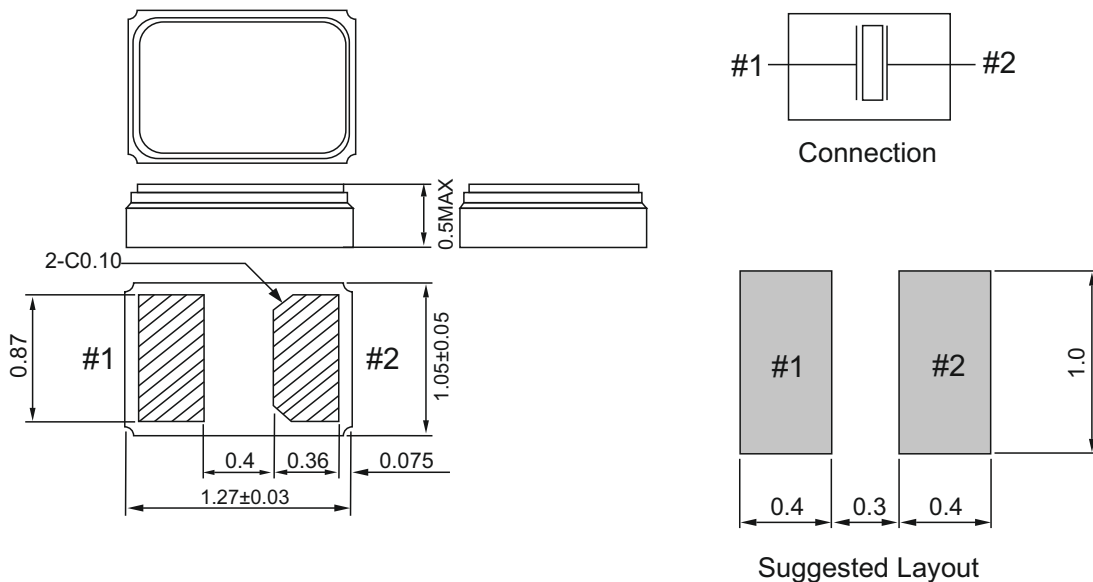

1.6 x 1.0 x 0.5 mm SMD Package

Feature

- Ultra small size 1.6x1.0x0.5 mm
- High reliability environmental performance
- High frequency stability and high precision
- Designed for automatic mounting and reflow soldering
- RoHS Compliant / Pb Free

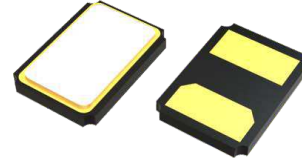

Electrical Specifications

Item	Specifications
Frequency	32.768kHz
Load Capacitance (CL)	6pF, 7pF, 9pF, 12.5pF
Frequency Tolerance(at 25°C)	±20ppm
Operating emperature Range	-40~+85°C
Turnover Temperature	25 ± 5°C
Frequency Temperature Curve	$(-0.036 \pm 10\%) \times 10^{-6} / ^\circ\text{C}^2$
Equivalent Series Resistance (ESR) max.	90kΩ
Drive Level (Typical)	0.1μW
Drive Level(Max)	0.5μW
Shunt Capacitance(C ₀)	1.2pF Typ.
Insulation esistance	More than 500Mohms at DC100V
Storage Temperature Range	-55°C~+125°C
Aging @25 °C 1st Year (Max)	±3ppm/year

Dimension(mm)

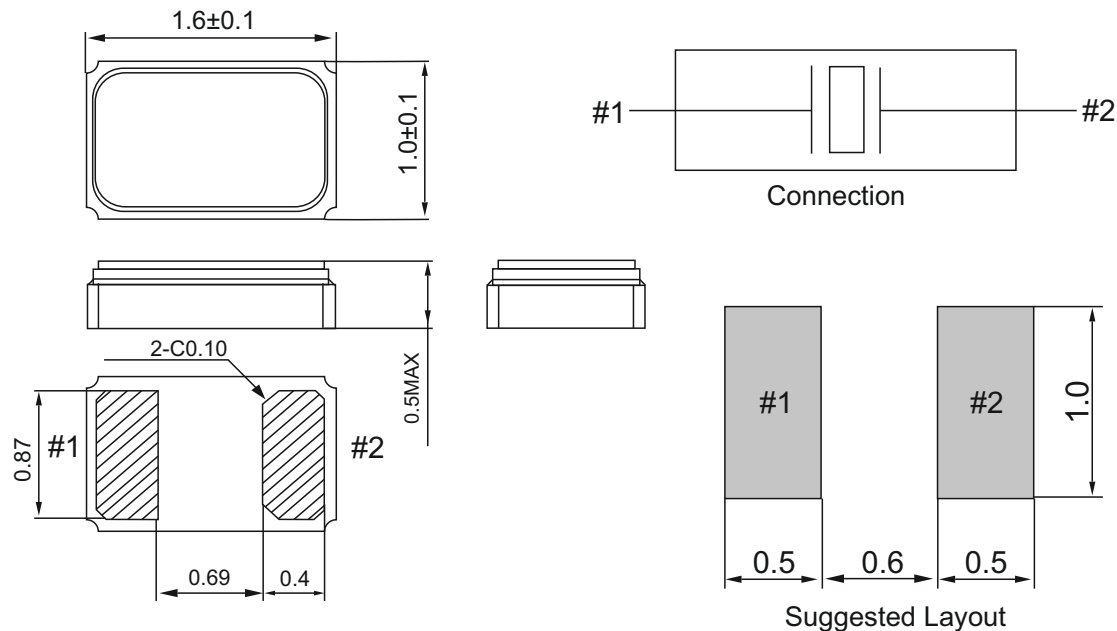

2.0 x 1.2 x 0.6 mm SMD Package

Feature

- Ultra small size 2.0*1.2*0.6 mm
- High reliability environmental performance.
- High frequency stability and high precision.
- Designed for automatic mounting and reflow soldering
- RoHS Compliant / Pb Free



Electrical Specifications

Item	Specifications
Frequency	32.768kHz
Load Capacitance (CL)	6pF, 7pF, 9pF , 12.5pF
Frequency Tolerance(at 25°C)	±20ppm
Operating emperature Range	-40~+85°C
Turnover Temperature	25 ± 5°C
Frequency Temperature Curve	$(-0.030 \pm 10\%) \times 10^6 / ^\circ\text{C}^2$
Equivalent Series Resistance (ESR) max.	90kΩ
Drive Level (Typical)	0.1μW
Drive Level(Max)	1.0μW
Shunt Capacitance(C ₀)	1.3pF Typ.
Insulation esistance	More than 500Mohms at DC100V
Storage Temperature Range	-55°C~+125°C
Aging @25°C 1st Year (Max)	±3ppm/year

Dimension(mm)

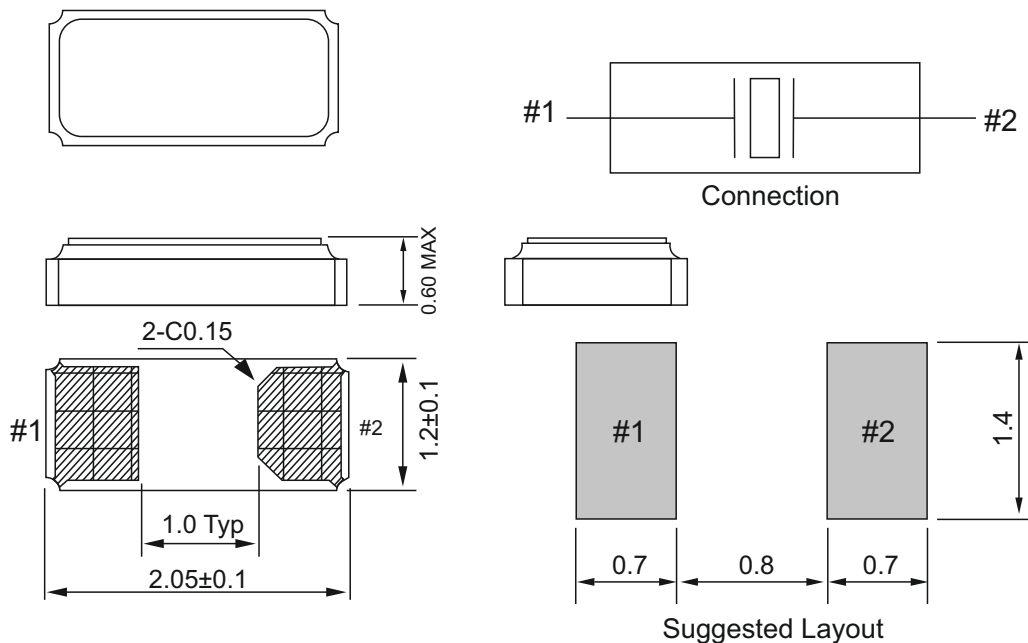

3.2 x 1.5 x 0.75 mm SMD Package

Feature

- Ultra small size 3.2*1.5*0.75 mm
- High reliability environmental performance.
- High frequency stability and high precision.
- Designed for automatic mounting and reflow soldering
- RoHS Compliant / Pb Free



Electrical Specifications

Item	Specifications
Frequency	32.768kHz
Load Capacitance (CL)	6pF, 7pF, 9pF , 12.5pF
Frequency Tolerance(at 25°C)	±20ppm
Operating emperature Range	-40~+85°C
Turnover Temperature	25 ± 5°C
Frequency Temperature Curve	$(-0.033 \pm 10\%) \times 10^6 / ^\circ\text{C}^2$
Equivalent Series Resistance (ESR) max.	50kΩ
Drive Level (Typical)	0.1μW
Drive Level(Max)	1.0μW
Shunt Capacitance(C ₀)	1.0pF Typ.
Insulation esistance	More than 500Mohms at DC100V
Storage Temperature Range	-55°C~+125°C
Aging @25°C 1st Year (Max)	±3ppm/year

Dimension(mm)

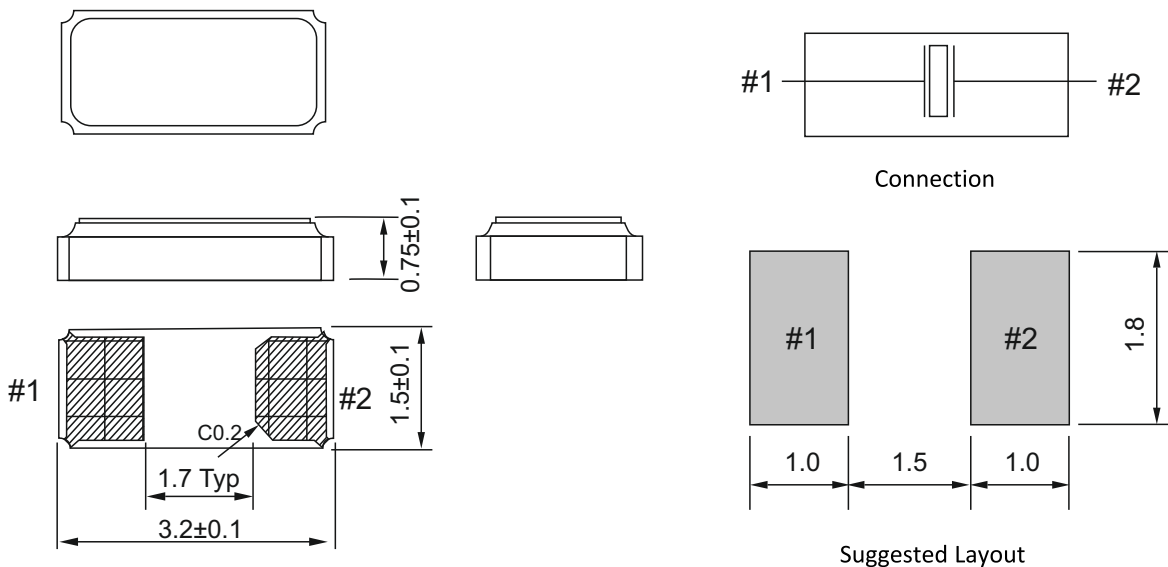

3.8 x 8.0 x 2.5 mm SMD Package

Feature

- Wide frequency range
- Designed for automatic mounting and reflow soldering
- Higher frequency available and lower equivalent series resistance
- RoHS Compliant / Pb Free



Electrical Specifications

Item	Specifications
Frequency Range (kHz)	30~40 40~60 60~70 70~200 200~350
Load Capacitance (CL)	6~12.5pF, or specify
Frequency Tolerance(at 25°C)	±5ppm ~ ±100ppm
Operating emperature Range	-10~+60°C, -20~+70°C, -40~+85°C or specify
Turnover Temperature	25 ± 5°C
Frequency Temperature Curve	$(-0.034 \pm 10\%) \times 10^{-6} / \pm^2$
Equivalent Series Resistance (ESR) Max.	40kΩ 30kΩ 25kΩ 22kΩ 20kΩ
Drive Level (Typical)	0.1μW
Drive Level(Max)	1μW
Shunt Capacitance (C ₀)	2.0pF Typ.
Insulation esistance	More than 500Mohms at DC100V
Storage Temperature Range	-55°C~+125°C
Aging @25 °C 1st Year (Max)	±3ppm/year, ±5 ppm/year,

Dimension(mm)

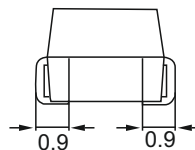
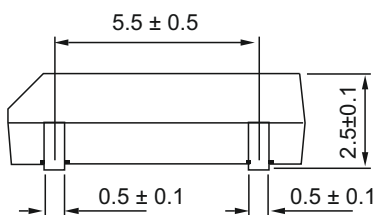
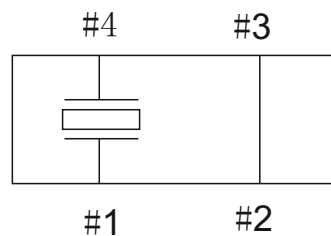
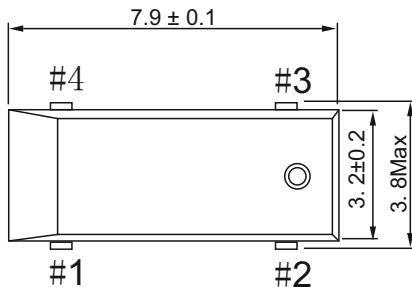

SOLDER PATTERN

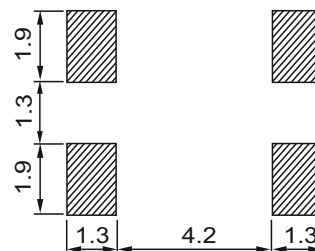

6.9 x 1.4 x 1.3 mm SMD Package

Feature

- Ultra small size 6.9x1.4x1.3 mm
- High reliability environmental performance
- High frequency stability and high precision
- Designed for automatic mounting and reflow soldering
- RoHS Compliant / Pb Free



Electrical Specifications

Item	Specifications
Frequency	32.768kHz
Load Capacitance (CL)	6pF, 7pF, 9pF, 12.5pF
Frequency Tolerance(at 25°C)	±5ppm , ±10ppm , ±20ppm
Operating emperature Range	-40~+85°C
Turnover Temperature	25 ± 5°C
Frequency Temperature Curve	$(-0.033 \pm 10\%) \times 10^{-6} / ^\circ\text{C}^2$
Equivalent Series Resistance (ESR) max.	65kΩ
Drive Level (Typical)	0.1μW
Drive Level(Max)	1μW
Shunt Capacitance(C ₀)	0.9pF Typ.
Insulation esistance	More than 500Mohms at DC100V
Storage Temperature Range	-55°C~+125°C
Aging @25 °C 1st Year (Max)	±3ppm/year

Dimension(mm)

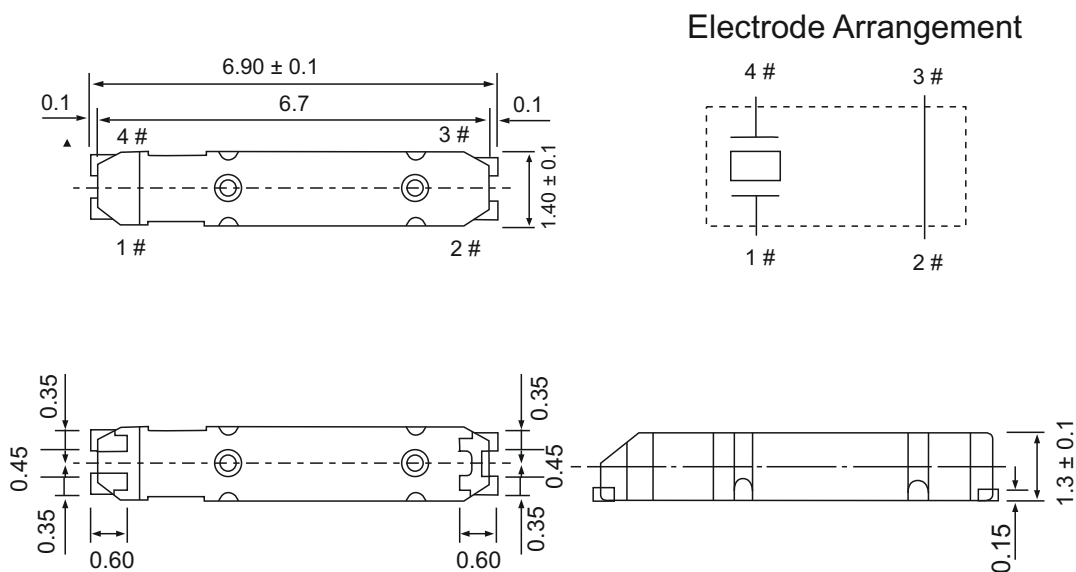

Φ2 x 6mm DIP Crystal

Feature

- Small size Φ2 x 6mm
- A great number of standard frequencies
- Higher frequency available and lower equivalent series resistance
- The best choice of Clock
- RoHS Compliant / Pb Free



Electrical Specifications

Item	Specifications				
	30~40	40~60	60~70	70~200	200~350
Frequency Range (kHz)					
Load Capacitance (CL)	6~12.5pF, or specify				
Frequency Tolerance(at 25°C)	±5ppm ~ ±100ppm				
Operating emperature Range	-20~+70°C or specify				
Turnover Temperature	25 ± 5°C				
Frequency Temperature Curve	$(-0.034 \pm 10\%) \times 10^{-6} / ^\circ\text{C}^2$				
Equivalent Series Resistance (ESR) Max.	40kΩ	30kΩ	25kΩ	22kΩ	20kΩ
Drive Level (Typical)	0.1μW				
Drive Level(Max)	1μW				
Shunt Capacitance (C ₀)	1.5 pF Typ.				
Insulation esistance	More than 500Mohms at DC100V				
Storage Temperature Range	-40°C~+85°C				
Aging @25 °C 1st Year (Max)	±3ppm/year, ±5 ppm/year,				

Dimension(mm)

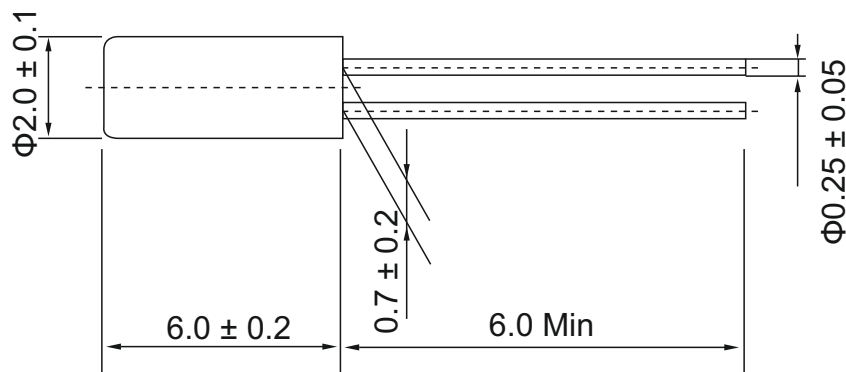

Φ3 x 8mm DIP Crystal

Feature

- Small size Φ3 x 8mm
- A great number of standard frequencies
- Higher frequency available and lower equivalent series resistance
- Lower cost and highly mass production capability
- The best choice of PC and Clock
- RoHS Compliant / Pb Free



Electrical Specifications

Item	Specifications
Frequency Range (kHz)	30~40 40~60 60~70 70~200 200~350
Load Capacitance (CL)	6~12.5pF, or specify
Frequency Tolerance(at 25°C)	±5ppm ~ ±100ppm
Operating emperature Range	-20~+70°C or specify
Turnover Temperature	25 ± 5°C
Frequency Temperature Curve	$(-0.034 \pm 10\%) \times 10^6 / ^\circ\text{C}^2$
Equivalent Series Resistance (ESR) Max.	40kΩ 30kΩ 25kΩ 22kΩ 20kΩ
Drive Level (Typical)	0.1μW
Drive Level (Max)	1μW
Shunt Capacitance (C ₀)	1.8 pF Typ.
Insulation esistance	More than 500Mohms at DC100V
Storage Temperature Range	-40°C~ +85°C
Aging @25°C 1st Year (Max)	±5 ppm/year,

Dimension(mm)

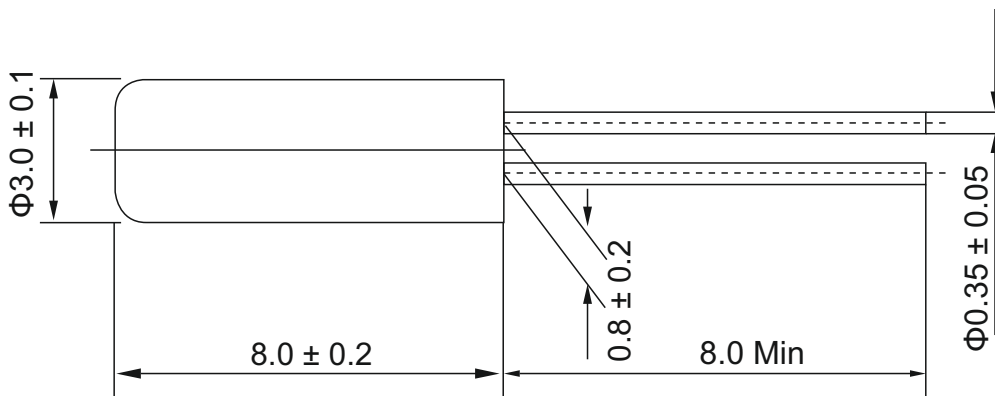

Φ2 x 6mm With Jacket Crystal

Feature

- Small size Φ 2 x 6mm SMD with Jacket
- Excellent frequency stability
- Designed for automatic mounting and reflow soldering
- RoHS Compliant / Pb Free



Electrical Specifications

Item	Specifications
Frequency	30~100kHz
Load Capacitance (CL)	6pF, 7pF, 9pF, 12.5pF or specify
Frequency Tolerance(at 25°C)	±20ppm or Specify
Operating emperature Range	-40~+85°C
Turnover Temperature	25 ± 5°C
Frequency Temperature Curve	$(-0.030 \pm 10\%) \times 10^6 / ^\circ\text{C}^2$
Equivalent Series Resistance (ESR) max.	50kΩ
Driver Level (Typical)	0.1μW
Driver Level(Max)	1.0μW
Shunt Capacitance(C ₀)	1.5pF Max.
Insulation esistance	More than 500Mohms at DC100V
Storage Temperature Range	-40°C ~+85°C
Aging @25 °C 1st Year (Max)	±5 ppm/year

Dimension(mm)

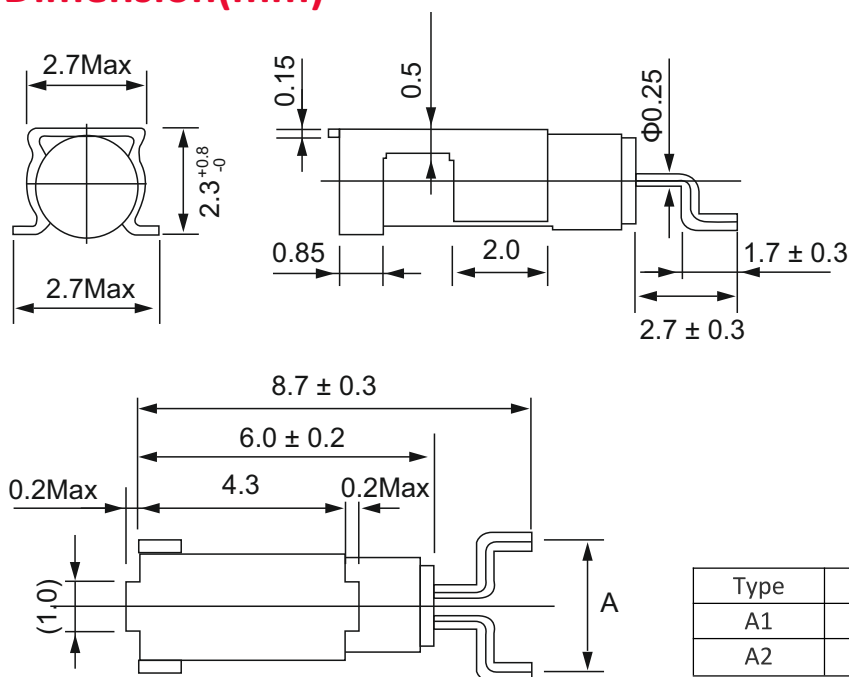

Φ2 x 6mm SMD Crystal

Feature

- Small size Φ2 x 6mm
- Wide frequency range: 30kHz~350kHz
- High reliability and high frequency stability
- Suited for automatic mounting and reflow soldering
- Environmentally friendly products, RoHS certified



Electrical Specifications

Item	Specifications
Frequency Range (kHz)	30~40 40~60 60~70 70~200 200~350
Load Capacitance (CL)	6~12.5pF, or specify
Frequency Tolerance(at 25°C)	±5ppm ~ ±100ppm
Operating emperature Range	-20~+70°C or specify
Turnover Temperature	25 ± 5°C
Frequency Temperature Curve	$(-0.035 \pm 10\%) \times 10^6 / ^\circ\text{C}^2$
Equivalent Series Resistance (ESR) Max.	40kΩ 30kΩ 25kΩ 22kΩ 20kΩ
Driver Level (Typical)	0.1μW
Driver Level(Max)	1μW
Shunt Capacitance (C ₀)	1.45 pF Typ.
Insulation esistance	More than 500Mohms at DC100V
Storage Temperature Range	-40°C~+85°C
Aging @25 °C 1st Year (Max)	±5 ppm/year,

Dimension(mm)

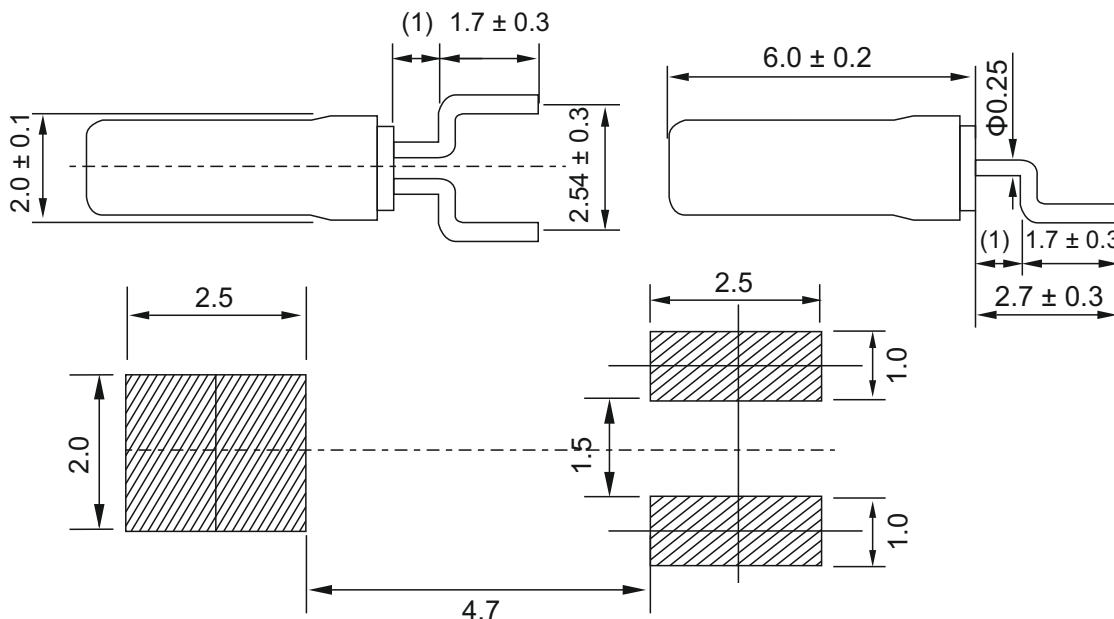

2.5 × 2.0 mm 32.768kHz SMD Crystal Oscillator

Feature

- Typical 2.5 x 2.0 x 0.81 mm SMD package.
- Tight symmetry (45 to 55%) available.
- Operation voltage: 1.8V, 2.5V, 3.3V
- Tri-state enable/disable
- Built-in ASIC enables reduction of current consumption

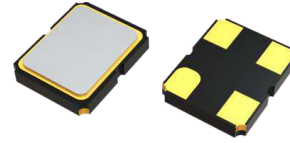

Electrical Specifications

Parameter	3.3V		2.5V		1.8V		Unit	
	Min.	Max.	Min.	Max.	Min.	Max.		
Supply Voltage Variation	2.97	3.63	2.25	2.75	1.62	1.98	V	
Supply Current	@ 15pF Load	-	70	-	66	-	63	uA
	@ no load	-	65	-	62	-	60	
Duty Cycle	45	55	45	55	45	55	%	
Transition Time :Rise/Fall Time	-	50	-	50	-	50	nSec	
Output Level	Out High(Logic"1")	2.97		2.25		1.62	V	
	Out Low(Logic"0")		0.33		0.25	0.18		
Startup Time	-	2	-	2	-	2	mSec	
Tri-State (Input to Pin 1)	Enable(High Voltage or floating)	2.31	-	1.75	-	1.26	V	
	Disable(Low Voltage or GND)	-	0.99	-	0.75	-		0.54
Aging(@25 1st year)	-	±3	-	±3	-	±3	ppm	
Storage Temp. Range	-55	125	-55	125	-55	125	°C	

Standard frequencies are frequencies which the crystal has been designed and does not imply a stock position
 .+ Transition times are measured between 10% and 90% of VDD, with an output load of 15pF.

Dimension(mm)

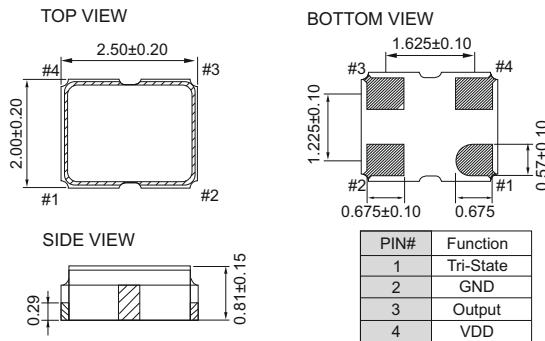

Solder Pad Layout(mm)

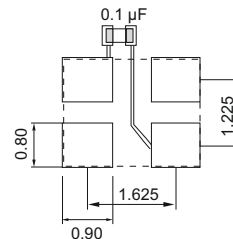

To ensure optimal oscillator performance, place a by-pass capacitor of 0.1 µF as close to the part as possible between Vdd and GND pads.

FREQ. STABILITY vs. TEMP. RANGE

Temp. (°C) \ ppm	±20	±25	±40	±50
-10 ~ +60	o	o	o	o
-20 ~ +70	Δ	o	o	o
-40 ~ +85	x	Δ	o	o
-40 ~ +125	x	x	Δ	o

o: Available Δ: Conditional X: Not available
 Inclusive of calibration @ 25 °C, operating temperature range, input voltage variation, load variation, aging (1st year), shock, and vibration load variation

3.2 × 2.5 mm 32.768kHz SMD Crystal Oscillator

Feature

- Typical 3.2 x 2.5 x 0.95 mm SMD package.
- Tight symmetry (45 to 55%) available.
- Operation voltage: 1.8V, 2.5V, 3.3V
- Tri-state enable/disable
- Built-in ASIC enables reduction of current consumption

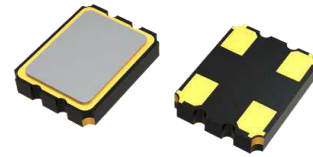

Electrical Specifications

Parameter	3.3V		2.5V		1.8V		Unit	
	Min.	Max.	Min.	Max.	Min.	Max.		
Supply Voltage Variation	2.97	3.63	2.25	2.75	1.62	1.98	V	
Supply Current	@ 15pF Load	-	70	-	66	-	63	uA
	@ no load	-	65	-	62	-	60	
Duty Cycle	45	55	45	55	45	55	%	
Transition Time : Rise/Fall Time	-	50	-	50	-	50	nSec	
Output Level	Out High (Logic "1")	2.97		2.25		1.62	V	
	Out Low (Logic "0")		0.33		0.25			0.18
Start Time	-	2	-	2	-	2	mSec	
Tri-State (Input to Pin 1)	Enable (High Voltage or floating)	2.31	-	1.75	-	1.26	V	
	Disable (Low Voltage or GND)	-	0.99	-	0.75	-		0.54
Aging (@25 1st year)	-	±3	-	±3	-	±3	ppm	
Storage Temp. Range	-55	125	-55	125	-55	125	°C	

Standard frequencies are frequencies which the crystal has been designed and does not imply a stock position.
 .+ Transition times are measured between 10% and 90% of VDD, with an output load of 15pF.

Dimension(mm)

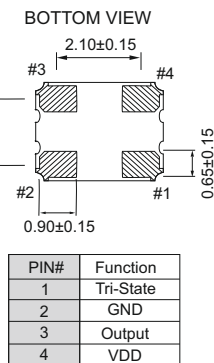
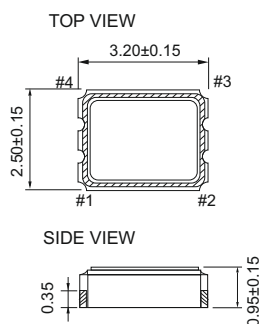

Solder Pad Layout(mm)

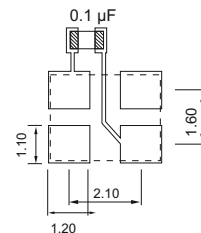

To ensure optimal oscillator performance, place a by-pass capacitor of 0.1 µF as close to the part as possible between Vdd and GND pads.

FREQ. STABILITY vs. TEMP. RANGE

Temp. (°C)	ppm			
	±20	±25	±40	±50
-10 ~ +60	○	○	○	○
-20 ~ +70	△	○	○	○
-40 ~ +85	X	△	○	○
-40 ~ +125	X	X	△	○

○: Available △: Conditional X: Not available
 Inclusive of calibration @ 25 °C, operating temperature range, input voltage variation, load variation, aging (1st year), shock, and vibration load variation

2.5 × 2.0 mm 32.768kHz Low Current Consumption SMD Oscillator

Feature

- Typical 2.5 x 2.0 x 0.81 mm SMD package.
- Low Power Supply Voltage: 3.3V, 2.5V, 1.8V
- Singled-end Output: CMOS
- Frequency: 32.768kHz
- Low Current Consumption: 18uA M x
- Temperature Range: -40 to 85 °C Operation
- Pb-free/RoHS Compliant

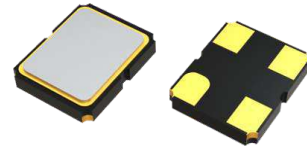

Electrical Specifications

Parameter	3.3V		2.5V		1.8V		Unit
	Min.	Max.	Min.	Max.	Min.	Max.	
Supply Voltage Variation	2.97	3.63	2.25	2.75	1.62	1.98	V
Supply Current(no load)	-	18	-	18	-	18	uA
Duty Cycle	45	55	45	55	45	55	%
Transition Time :Rise/Fall Time	-	15	-	15	-	15	nSec
Output Level	Out High(Logic"1")		2.25		1.62		V
	Out Low(Logic"0")		0.33		0.25		
Startup Time	-	20	-	20	-	20	mSec
Standby Current	-	3	-	3	-	3	uA
Output Loading(CMOS)	-	15	-	15	-	15	pF
Tri-State (Input to Pin 2)	Enable	2.31	-	1.75	-	1.26	V
	Disable	-	0.99	-	0.75	-	
Aging(@25 1st year)	-	±3	-	±3	-	±3	ppm
Storage Temp. Range	-55	125	-55	125	-55	125	°C

Dimension(mm)

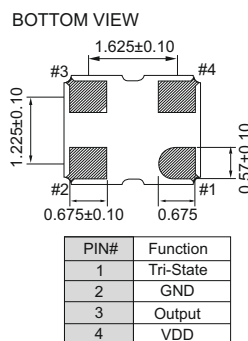
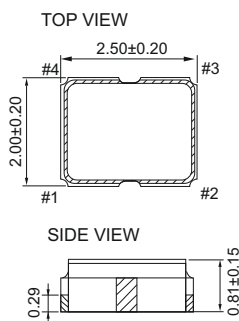

Solder Pad Layout(mm)

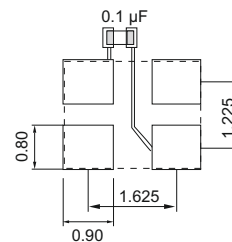

To ensure optimal oscillator performance, place a by-pass capacitor of 0.1 µF as close to the part as possible between Vdd and GND pads.

FREQ. STABILITY vs. TEMP. RANGE

Temp. (°C)	ppm		
	±20	±25	±50
-10 ~ +60	○	○	○
-20 ~ +70	○	○	○
-40 ~ +85	△	○	○

○: Available △: Conditional X: Not available

Inclusive of calibration @ 25 °C, operating temperature range, input voltage variation, load variation, aging (1st year), shock, and vibration

3.2 × 2.5 mm 32.768kHz Low Current Consumption SMD Oscillator

Feature

- Typical 3.2 x 2.5 x 0.95 mm SMD package.
- Low Power Supply Voltage: 3.3V, 2.5V, 1.8V
- Singled-end Output: CMOS
- Frequency: 32.768kHz
- Low Current Consumption: 10uA M x
- Temperature Range: -40 to 125 °C Operation
- Pb-free/RoHS Compliant

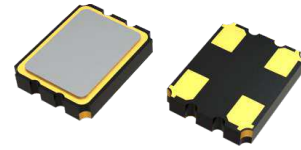

Electrical Specifications

Parameter	3.3V		2.5V		1.8V		Unit
	Min.	Max.	Min.	Max.	Min.	Max.	
Supply Voltage Variation	V _{DD} -10%	V _{DD} +10%	V _{DD} -5%	V _{DD} +5%	V _{DD} -5%	V _{DD} +5%	V
Supply Current(no load)	-	18	-	18	-	18	uA
Duty Cycle	45	55	45	55	45	55	%
Transition Time :Rise/Fall Time	-	15	-	15	-	15	nSec
Output Level	Out High(Logic"1")		2.25		1.62		V
	Out Low(Logic"0")		0.33		0.25		
Startup Time	-	20	-	20	-	20	mSec
Standby Current	-	3	-	3	-	3	uA
Output Loading(CMOS)	-	15	-	15	-	15	pF
Tri-State (Input to Pin 2)	Enable	2.31	-	1.75	-	1.26	V
	Disable	-	0.99	-	0.75	-	
Aging(@25 1st year)	-	±3	-	±3	-	±3	ppm
Storage Temp. Range	-55	125	-55	125	-55	125	°C

Dimension(mm)

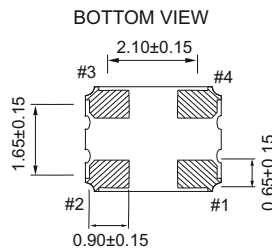
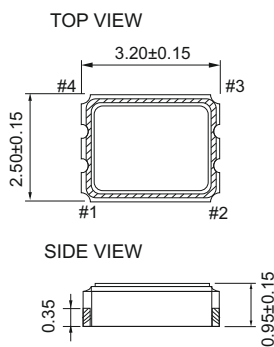

PIN#	Function
1	Tri-State
2	GND
3	Output
4	VDD

Solder Pad Layout(mm)

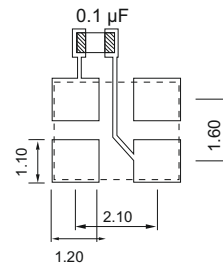

To ensure optimal oscillator performance, place a by-pass capacitor of 0.1 µF as close to the part as possible between Vdd and GND pads.

FREQ. STABILITY vs. TEMP. RANGE

Temp. (°C) \ ppm	±20	±25	±30	±50
-10 ~ +60	○	○	○	○
-20 ~ +70	△	○	○	○
-40 ~ +85	X	△	○	○
-40 ~ +105	X	X	△	○
-40 ~ +125	X	X	X	○

○: Available △: Conditional X: Not available
 Inclusive of calibration @ 25 °C, operating temperature range, input voltage variation, load variation, aging (1st year), shock, and vibration

SMD Crystal Oscillator 2.0 ×1.6 mm

Feature

- Typical 2.05 x 1.65 x 0.75 mm SMD package.
- Tight symmetry (45 to 55%) available.
- Operation voltage: 1.8V, 2.5V, 3.3V
- Tri-state enable/disable
- RoHS compliant/Pb-free

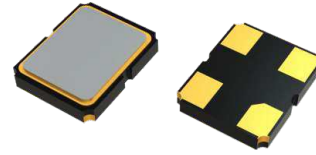

Electrical Specifications

Parameter	3.3V		2.5V		1.8V		Unit	
	Min.	Max.	Min.	Max.	Min.	Max.		
Supply Voltage Variation	2.97	3.63	2.25	2.75	1.62	1.98	V	
Frequency Range	1.5	50	1.5	50	1.5	50	MHz	
Standard Frequency	24,26,32,40						MHz	
Supply Current	-	15	-	10	-	7	mA	
Duty Cycle	45	55	45	55	45	55	%	
Transition Time :	1.5 MHz ≅ FO<20MHz	-	4	-	4	-	5	nSec
	Rise/Fall Time	20 MHz ≅ FO<50MHz	-	3	-	3	-	
Output Level (CMOS)	Output High(Logic"1")	2.97		2.25		1.62		V
	Output Low(Logic"0")		0.33		0.25		0.18	
Start Time	-	2	-	2	-	2	mSec	
Tri-State (Input to Pin 1)	Enable(High Voltage or floating)	2.31	-	1.75	-	1.26	-	V
	Disable(Low Voltage or GND)	-	0.99	-	0.75	-	0.54	
Period Jitter (PK-Pk)	-	40	-	40	-	40	pSec	
RMS Phase Jitter (integrated 12kHz to 20MHz)	-	1	-	1	-	1	pSec	
Standby Current	-	10	-	10	-	10	µA	
Aging(@25 1st year)	-	±3	-	±3	-	±3	ppm	
Storage Temp. Range	-55	125	-55	125	-55	125	°C	

Standard frequencies are frequencies which the crystal has been designed and does not imply a stock position
 .+ Transition times are measured between 10% and 90% of VDD, with an output load of 15pF.

Dimension(mm)

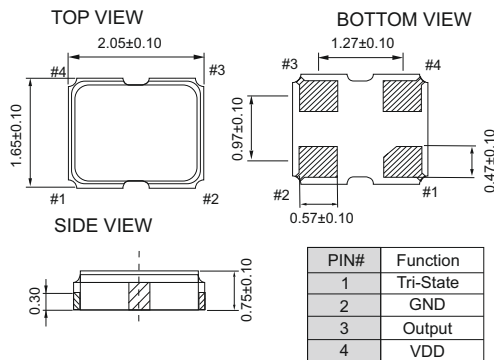

Solder Pad Layout(mm)

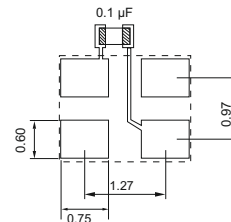

To ensure optimal oscillator performance, place a by-pass capacitor of 0.1 µF as close to the part as possible between Vdd and GND pads.

FREQ. STABILITY vs. TEMP. RANGE

Temp. (°C) \ ppm	±20	±25	±50
-10 ~ +60	o	o	o
-20 ~ +70	Δ	o	o
-40 ~ +85	X	o	o
-40 ~ +125	X	X	o

o: Available Δ: Conditional X: Not available
 Inclusive of calibration @ 25 °C, operating temperature range, input voltage variation, load variation, aging (1st year), shock, and vibration

SMD Crystal Oscillator 2.5 x 2.0 mm

Feature

- Typical 2.5 x 2.0 x 0.81 mm SMD package.
- Tight symmetry (45 to 55%) available.
- Operation voltage: 1.8V, 2.5V, 3.3V
- Tri-state enable/disable
- RoHS compliant/Pb-free

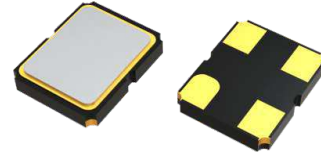

Electrical Specifications

Parameter	3.3V		2.5V		1.8V		Unit	
	Min.	Max.	Min.	Max.	Min.	Max.		
Supply Voltage Variation	3.135	3.465	2.375	2.625	1.71	1.89	V	
Frequency Range	1.25	125	1.25	125	1.25	125	MHz	
Standard Frequency	24,26,30,40						MHz	
Supply Current(At 15pF Load)	-	15	-	10	-	7	mA	
Duty Cycle	45	55	45	55	45	55	%	
Transition Time : Rise/Fall Time	1.25 MHz ≤ FO < 10MHz	-	3	-	4	-	5	nSec
	10 MHz ≤ FO < 125MHz	-	3	-	3	-	4	
Output Level	Out High	2.97		2.25		1.62	V	
	Out Low		0.33		0.25			0.18
Start Time	-	2	-	2	-	2	mSec	
Tri-State (Input to Pin 1)	Enable(High Voltage or floating)	2.31	-	1.75	-	1.26	-	V
	Disable(Low Voltage or GND)	-	0.99	-	0.75	-	0.54	
Period Jitter (Pk-Pk)	-	40	-	40	-	40	pSec	
RMS Phase Jitter (integrated 12kHz to 20MHz)	-	1	-	1	-	1	pSec	
Standby Current(@-40 to 85°C)	-	10	-	10	-	10	µA	
Standby Current(@-40 to 125°C)	-	20	-	20	-	20	µA	
Aging(@25 1st year)	-	±3	-	±3	-	±3	ppm	
Storage Temp. Range	-55	125	-55	125	-55	125	°C	

Standard frequencies are frequencies which the crystal has been designed and does not imply a stock position

.+ Transition times are measured between 10% and 90% of VDD, with an output load of 15pF.

Dimension(mm)

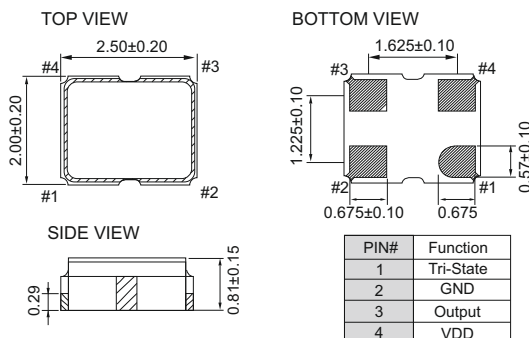

Solder Pad Layout(mm)

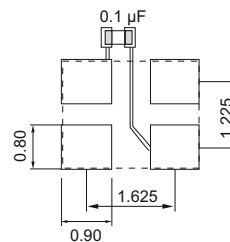

To ensure optimal oscillator performance, place a by-pass capacitor of 0.1 µF as close to the part as possible between Vdd and GND pads.

FREQ. STABILITY vs. TEMP. RANGE

Temp. (°C)	ppm		
	±20	±25	±50
-10 ~ +60	○	○	○
-20 ~ +70	△	○	○
-40 ~ +85	X	○	○
-40 ~ +125	X	X	○

○: Available △: Conditional X: Not available

Inclusive of calibration @ 25 °C, operating temperature range, input voltage variation, load variation, aging (1st year), shock, and vibration load variation

3.2 × 2.5 mm SMD Crystal Oscillator

Feature

- Typical 3.2 x 2.5 x 0.95mm SMD package.
- Tight symmetry (45 to 55%) available.
- Operation voltage: 1.8V, 2.5V, 3.3V
- Tri-state enable/disable
- RoHS compliant/Pb-free

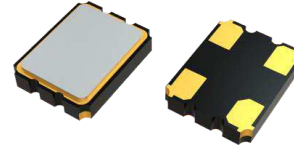

Electrical Specifications

Parameter	3.3V		2.5V		1.8V		Unit
	Min.	Max.	Min.	Max.	Min.	Max.	
Supply Voltage Variation	3.135	3.465	2.375	2.625	1.71	1.89	V
Frequency Range	1.25	125	1.25	125	1.25	125	MHz
Standard Frequency	4,24,26,32,38,40						MHz
Supply Current(At 15pF Load)	-	15	-	10	-	7	mA
Duty Cycle	45	55	45	55	45	55	%
Transition Time :	1.25 MHz ≤ FO < 10MHz						nSec
Rise/Fall Time	10 MHz ≤ FO < 125MHz						
Output Level	Out High(Logic"1")		2.25		1.62		V
	Out Low(Logic"0")		0.33		0.18		
Start Time	-	2	-	2	-	2	mSec
Tri-State (Input to Pin 1)	Enable(High Voltage or floating)		2.31		1.26		V
	Disable(Low Voltage or GND)		- 0.99		- 0.54		
Period Jitter (Pk-Pk)	-	40	-	40	-	40	pSec
RMS Phase Jitter (integrated 12kHz to 20MHz)	-	1	-	1	-	1	pSec
Standby Current(@-40 to 85°C)	-	10	-	10	-	10	µA
Standby Current(@-40 to 125°C)	-	20	-	20	-	20	µA
Aging(@25 1st year)	-	±3	-	±3	-	±3	ppm
Storage Temp. Range	-55	125	-55	125	-55	125	°C

Standard frequencies are frequencies which the crystal has been designed and does not imply a stock position

• Transition times are measured between 10% and 90% of VDD, with an output load of 15pF.

Dimension(mm)

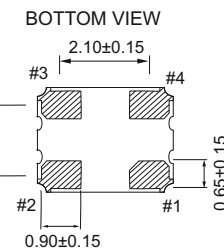
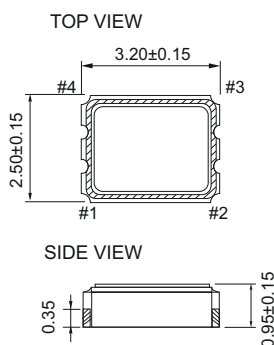

PIN#	Function
1	Tri-State
2	GND
3	Output
4	VDD

Solder Pad Layout(mm)

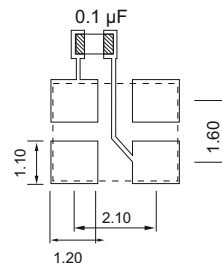

To ensure optimal oscillator performance, place a by-pass capacitor of 0.1 µF as close to the part as possible between Vdd and GND pads.

FREQ. STABILITY vs. TEMP. RANGE

Temp. (°C)	ppm		
	±20	±25	±50
-10 ~ +60	o	o	o
-20 ~ +70	Δ	o	o
-40 ~ +85	X	o	o
-40 ~ +125	X	X	o

o: Available Δ: Conditional X: Not available

Inclusive of calibration @ 25 °C, operating temperature range, input voltage variation, load variation, aging (1st year), shock, and vibration load variation

5.0 × 3.2 mm SMD Crystal Oscillator

Feature

- Typical 5.0 x 3.2 x 1.2mm ceramic SMD package
- Tight symmetry (45 to 55%) available
- Operation voltage: 1.8V, 2.5V, 3.3V
- Realize the standby function with Tri-State
- RoHS compliant/Pb-free



Electrical Specifications

Parameter	3.3V		2.5V		1.8V		Unit
	Min.	Max.	Min.	Max.	Min.	Max.	
Supply Voltage Variation	2.97	3.63	2.25	2.75	1.62	1.98	V
Frequency Range	0.0137	160	0.0137	160	0.0137	135	MHz
Standard Frequency	2.048, 25, 26, 27, 50, 66.667, 100, 125						MHz
Supply Current	13.7kHz ≦ FO < 93kHz		-	1	-	1	mA
	0.3125MHz ≦ FO < 50MHz		-	10	-	8	
	40 MHz ≦ FO < 75MHz		-	20	-	18	
	75 MHz ≦ FO < 135MHz		-	35	-	30	
	135 MHz ≦ FO		-	45	-	40	
Transition Time : Rise/Fall Time	13.7kHz ≦ FO < 93kHz		-	50	-	50	nSec
	0.3125 MHz ≦ FO < 100MHz		-	5	-	5	
	100 MHz ≦ FO		-	3	-	3	
Output Level (CMOS)	Out High (Logic "1")		2.97		2.25		V
	Out Low (Logic "0")			0.33		0.25	
Start Time	-	5	-	5	-	5	mSec
Tri-State (Input to Pin 1)	Enable (High Voltage or floating)		2.31	-	1.75	-	V
	Disable (Low Voltage or GND)		-	0.99	-	0.75	
Period Jitter (Pk-Pk)	-	40	-	40	-	40	pSec
RMS Phase Jitter (integrated 12kHz to 20MHz)	-	1	-	1	-	1	pSec
Standby Current	-	10	-	10	-	10	µA
Aging (@25 1st year)	-	±3	-	±3	-	±3	ppm
Storage Temp. Range	-55	125	-55	125	-55	125	°C

Standard frequencies are frequencies which the crystal has been designed and does not imply a stock position
 .+ Transition times are measured between 10% and 90% of VDD, with an output load of 15pF.

Dimension (mm)

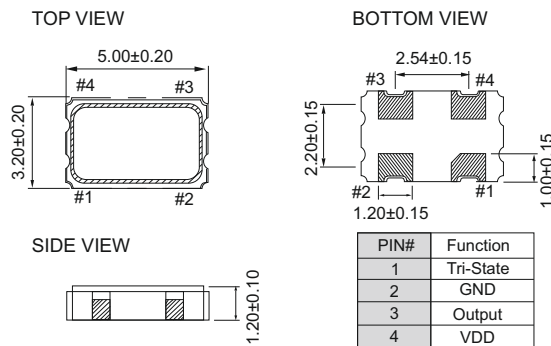

Solder Pad Layout (mm)

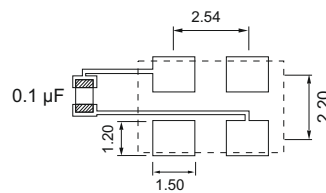

To ensure optimal oscillator performance, place a by-pass capacitor of 0.1 µF as close to the part as possible between Vdd and GND pads.

FREQ. STABILITY vs. TEMP. RANGE

ppm / Temp. (°C)	±20	±25	±50
10 ~ +60	○	○	○
-20 ~ +70	△	○	○
-40 ~ +85	△	○	○
-40 ~ +125	X	X	○

○: Available △: Conditional X: Not available
 Inclusive of calibration @ 25 °C, operating temperature range, input voltage variation, load variation, aging (1st year), shock, and vibration

7.0 x 5.0 mm SMD Crystal Oscillator

Feature

- Typical 7.0 x 5.0 x 1.3mm SMD package.
- Operation voltage: 1.8V, 2.5V, 3.3V
- Tri-state enable/disable
- Output frequency up to 166MHz
- RoHS compliant/Pb-free



Electrical Specifications

Parameter	3.3V		2.5V		1.8V		Unit	
	Min.	Max.	Min.	Max.	Min.	Max.		
Supply Voltage Variation	2.97	3.63	2.25	2.75	1.62	1.98	V	
Frequency Range	0.0137	166	0.0137	133	0.0137	125	MHz	
Standard Frequency	2,048,25,26,27,50,66.667,100,125						MHz	
Supply Current	13.7kHz \leq FO < 70kHz	-	1	-	1	-	1	mA
	0.312MHz \leq FO < 35.328MHz	-	10	-	8	-	7	
	40 MHz \leq FO < 75MHz	-	20	-	18	-	15	
	75 MHz \leq FO < 135MHz	-	35	-	30	-	25	
	135 MHz \leq FO	-	45	-	40	-	-	
Transition Time : Rise/Fall Time	13.7kHz \leq FO < 93kHz	-	50	-	50	-	50	nSec
	0.312 MHz \leq FO < 100MHz	-	5	-	5	-	5	
	100 MHz \leq FO	-	3	-	3	-	3	
Output Level (CMOS)	Output High(Logic"1")	2.97		2.25		1.62		V
	Output Low(Logic"0")		0.33		0.25		0.18	
Start Time		-	5	-	5	-	5	mSec
Tri-State (Input to Pin 1)	Enable(High Voltage or floating)	2.31	-	1.75	-	1.26	-	V
	Disable(Low Voltage or GND)	-	0.99	-	0.75	-	0.54	
Period Jitter (Pk-Pk)		-	40	-	40	-	40	pSec
RMS Phase Jitter (Integrated 12kHz to 20MHz)		-	1	-	1	-	1	pSec
Standby Current		-	10	-	10	-	10	μ A
Aging(@25 1st year)		-	\pm 3	-	\pm 3	-	\pm 3	ppm
Storage Temp. Range		-55	125	-55	125	-55	125	$^{\circ}$ C

Standard frequencies are frequencies which the crystal has been designed and does not imply a stock position
 .+ Transition times are measured between 10% and 90% of VDD, with an output load of 15pF.

Dimension(mm)

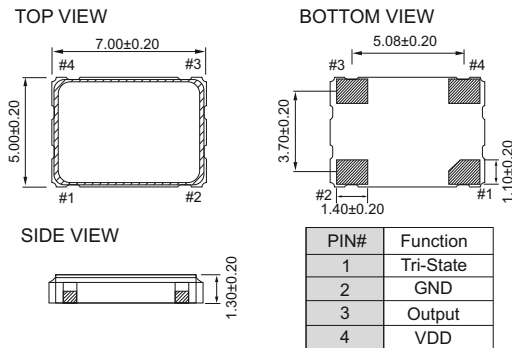

Solder Pad Layout(mm)

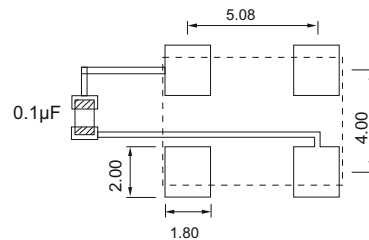

To ensure optimal oscillator performance, place a by-pass capacitor of 0.1 µF as close to the part as possible between Vdd and GND pads.

FREQ. STABILITY vs. TEMP. RANGE

Temp. ($^{\circ}$ C)	ppm \pm 20	ppm \pm 25	ppm \pm 50
10 ~ +60	o	o	o
-20 ~ +70	Δ	o	o
-40 ~ +85	Δ	o	o
-40 ~ +125	X	X	o

o: Available Δ: Conditional X: Not available
 Inclusive of calibration @ 25 $^{\circ}$ C, operating temperature range, input voltage variation, load variation, aging (1st year), shock, and vibration

2.5 × 2.0 mm Ultra Low Power SMD Crystal Oscillator

Feature

- Typical 2.5 x 2.0 x 0.81 mm SMD package
- Singled-end Output: CMOS
- Ultra Low Power Supply Voltage: 0.9V, 1.2V, 1.5V
- Low Noise Typical: 0.3ps at 12kHz to 20MHz Frequency Offsets
- Temperature Range: -40 to 85°C Operation
- Pb-free/RoHS Compliant

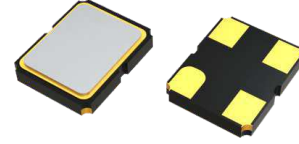

Electrical Specifications

Parameter	0.9V		1.2V		1.5V		Unit	
	Min.	Max.	Min.	Max.	Min.	Max.		
Supply Voltage Variation	V _{DD} -5%	V _{DD} +5%	V _{DD} -5%	V _{DD} +5%	V _{DD} -5%	V _{DD} +5%	V	
Frequency Range	1	50	1	50	1	50	MHz	
Supply Current(At 15pF Load)	-	1.5	-	2	-	3	mA	
Duty Cycle	45	55	45	55	45	55	%	
Transition Time : Rise/Fall Time	1 MHz ≦ FO < 10MHz	-	4	-	3	-	3	nSec
	10 MHz ≦ FO < 20MHz	-	3	-	3	-	3	
	20 MHz ≦ FO < 50MHz	-	2	-	2	-	2	
Output Level	Out High	0.9V _{DD}		0.9V _{DD}		0.9V _{DD}		V
	Out Low	0.1V _{DD}		0.1V _{DD}		0.1V _{DD}		
Startup Time	-	4	-	4	-	4	mSec	
Tri-State (Input to Pin 1)	Enable	0.7V _{DD}		0.7V _{DD}		0.7V _{DD}		V
	Disable	0.3V _{DD}		0.3V _{DD}		0.3V _{DD}		
Period Jitter (Pk-Pk)	-	40	-	40	-	40	pSec	
RMS Phase Jitter (integrated 12kHz to 20MHz)	-	1	-	1	-	1	pSec	
Phase Noise @24MHz @100kHz	-148		-150		-150		dBc/Hz	
Standby Current	-	100	-	100	-	100	µA	
Aging(@25 1st year)	-	±3	-	±3	-	±3	ppm	
Storage Temp. Range	-55	125	-55	125	-55	125	°C	

Standard frequencies are frequencies which the crystal has been designed and does not imply a stock position
 .+ Transition times are measured between 10% and 90% of VDD, with an output load of 15pF.

Dimension(mm)

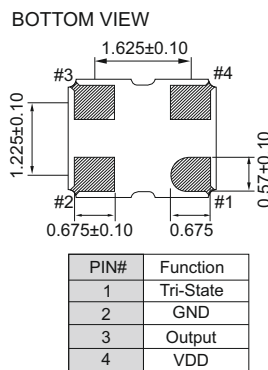
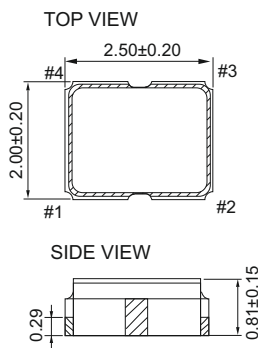

Solder Pad Layout(mm)

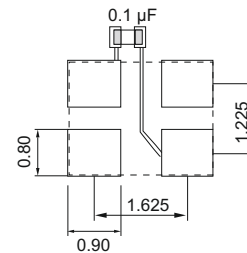

To ensure optimal oscillator performance, place a by-pass capacitor of 0.1 µF as close to the part as possible between Vdd and GND pads.

FREQ. STABILITY vs. TEMP. RANGE

Temp. (°C)	ppm	
	±25	±50
-10 ~ +60	o	o
-20 ~ +70	o	o
-40 ~ +85	Δ	o

o: Available Δ: Conditional X: Not available
 Inclusive of calibration @ 25 °C, operating temperature range, input voltage variation, load variation, aging (1st year), shock, and vibration load variation

3.2 × 2.5 mm Ultra Low Power SMD Crystal Oscillator

Feature

- Typical 3.2 x 2.5 x 0.95 mm SMD package
- Singled-end Output: CMOS
- Ultra Low Power Supply Voltage: 0.9V, 1.2V, 1.5V
- Low Noise Typical: 0.3ps at 12kHz to 20MHz Frequency Offsets
- Temperature Range: -40 to 85°C Operation
- Pb-free/RoHS Compliant

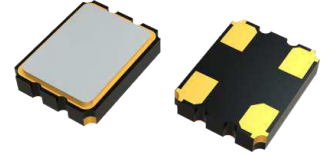

Electrical Specifications

Parameter	0.9V		1.2V		1.5V		Unit	
	Min.	Max.	Min.	Max.	Min.	Max.		
Supply Voltage Variation	V _{DD} -5%	V _{DD} +5%	V _{DD} -5%	V _{DD} +5%	V _{DD} -5%	V _{DD} +5%	V	
Frequency Range	1	50	1	50	1	50	MHz	
Supply Current(At 15pF Load)	-	1.5	-	2	-	3	mA	
Duty Cycle	45	55	45	55	45	55	%	
Transition Time : Rise/Fall Time	1 MHz ≅ FO<10MHz	-	4	-	3	-	3	nSec
	10 MHz ≅ FO<20MHz	-	3	-	3	-	3	
	20 MHz ≅ FO<50MHz	-	2	-	2	-	2	
Output Level	Out High	0.9V _{DD}		0.9V _{DD}		0.9V _{DD}		V
	Out Low	0.1V _{DD}		0.1V _{DD}		0.1V _{DD}		
Startup Time	-	4	-	4	-	4	mSec	
Tri-State (Input to Pin 1)	Enable	0.7V _{DD}		0.7V _{DD}		0.7V _{DD}		V
	Disable	0.3V _{DD}		0.3V _{DD}		0.3V _{DD}		
Period Jitter (Pk-Pk)	-	40	-	40	-	40	pSec	
RMS Phase Jitter (integrated 12kHz to 20MHz)	-	1	-	1	-	1	pSec	
Phase Noise @24MHz @100kHz	-148		-150		-150		dBc/Hz	
Standby Current	-	100	-	100	-	100	µA	
Aging(@25 1st year)	-	±3	-	±3	-	±3	ppm	
Storage Temp. Range	-55	125	-55	125	-55	125	°C	

Standard frequencies are frequencies which the crystal has been designed and does not imply a stock position
 .+ Transition times are measured between 10% and 90% of VDD, with an output load of 15pF.

Dimension(mm)

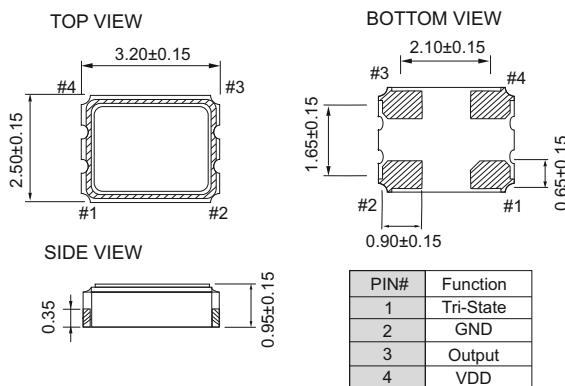

Solder Pad Layout(mm)

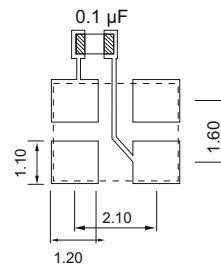

To ensure optimal oscillator performance, place a by-pass capacitor of 0.1 µF as close to the part as possible between Vdd and GND pads.

FREQ. STABILITY vs. TEMP. RANGE

Temp. (°C) \ ppm	±25	±50
-10 ~ +60	○	○
-20 ~ +70	○	○
-40 ~ +85	△	○

○: Available △: Conditional X: Not available
 Inclusive of calibration @ 25 °C, operating temperature range, input voltage variation, load variation, aging (1st year), shock, and vibration load variation

2.5 × 2.0 mm Extended Operating Temperature Range SMD Crystal Oscillator

Feature

- Typical 2.5 x 2.0 x 0.81 mm SMD package.
- Extended Industrial Operating temperature Range -55~+125°C
- Low jitter and phase noise(25ps Pk-Pk Period jitter, typical)
- Tight symmetry(45 to 55%) available.
- Operation voltage : 1.8V, 2.5V, 3.3V.
- Tri-state enable/disable.

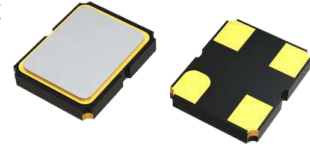

Electrical Specifications

Parameter	3.3V		2.5V		1.8V		Unit	
	Min.	Max.	Min.	Max.	Min.	Max.		
Supply Voltage Variation	2.97	3.63	2.25	2.75	1.62	1.98	V	
Frequency Range	1.25	100	1.25	100	1.25	100	MHz	
Supply Current	FO<80MHz	-	10	-	8	-	5	mA
	80 MHz ≤ FO	-	15	-	10	-	8	mA
Duty Cycle	45	55	45	55	45	55	%	
Transition Time : Rise/Fall Time	-	3	-	4	-	5	nSec	
Output Level (CMOS)	Output High(Logic"1")	2.97		2.25		1.62	V	
	Output Low(Logic"0")		0.33		0.25			0.18
Start Time	-	2	-	2	-	2	mSec	
Tri-State (Input to Pin 1)	Enable(High Voltage or floating)	2.31	-	1.75	-	1.26	V	
	Disable(Low Voltage or GND)	-	0.99	-	0.75	-		0.54
Period Jitter (Pk-Pk)	-	40	-	40	-	40	pSec	
RMS Phase Jitter (integrated 12kHz to 20MHz)	-	1	-	1	-	1	pSec	
Aging(@25 1st year)	-	±3	-	±3	-	±3	ppm	
Storage Temp. Range	-55	125	-55	125	-55	125	°C	

Standard frequencies are frequencies which the crystal has been designed and does not imply a stock position.
 .+ Transition times are measured between 10% and 90% of VDD, with an output load of 15pF.

Dimension(mm)

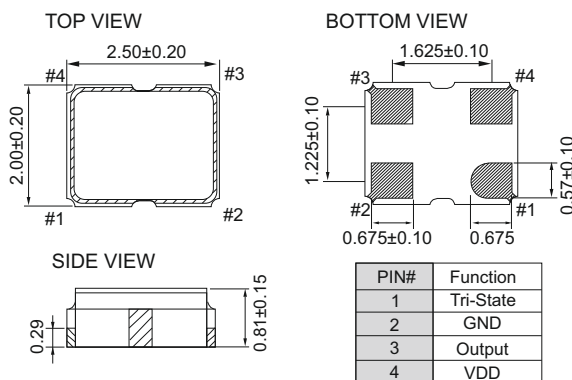

Solder Pad Layout(mm)

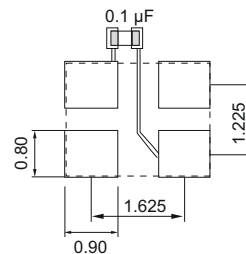

To ensure optimal oscillator performance, place a by-pass capacitor of 0.1 µF as close to the part as possible between Vdd and GND pads.

FREQ. STABILITY vs. TEMP. RANGE

Temp. (°C) \ ppm	±30	±40	±50	±100
-40 ~ +85	○	○	○	○
-40 ~ +105	△	○	○	○
-40 ~ +125	X	△	○	○
-55 ~ +125	X	X	△	○

○: Available △: Conditional X: Not available
 Inclusive of calibration @ 25 °C, operating temperature range, input voltage variation, load variation, aging (1st year), shock, and vibration

3.2 × 2.5 mm Extended Operating Temperature Range SMD Crystal Oscillator

Feature

- Typical 3.2 x 2.5 x 0.95 mm SMD package.
- Extended Industrial Operating temperature Range -55~+125°C
- Low jitter and phase noise(25ps Pk-Pk Period jitter, typical)
- Tight symmetry(45 to 55%) available.
- Operation voltage : 1.8V, 2.5V, 3.3V.
- Tri-state enable/disable.

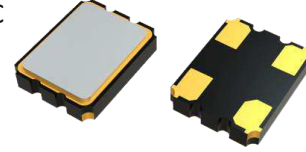

Electrical Specifications

Parameter	3.3V		2.5V		1.8V		Unit	
	Min.	Max.	Min.	Max.	Min.	Max.		
Supply Voltage Variation	2.97	3.63	2.25	2.75	1.62	1.98	V	
Frequency Range	1.25	100	1.25	100	1.25	100	MHz	
Supply Current	FO<80MHz	-	10	-	8	-	5	mA
	80 MHz ≤ FO	-	15	-	10	-	8	mA
Duty Cycle	45	55	45	55	45	55	%	
Transition Time : Rise/Fall Time	-	3	-	4	-	5	nSec	
Output Level (CMOS)	Output High(Logic"1")	2.97		2.25		1.62	V	
	Output Low(Logic"0")		0.33		0.25			0.18
Start Time	-	2	-	2	-	2	mSec	
Tri-State (Input to Pin 1)	Enable(High Voltage or floating)	2.31	-	1.75	-	1.26	V	
	Disable(Low Voltage or GND)	-	0.99	-	0.75	-		0.54
Period Jitter (Pk-Pk)	-	40	-	40	-	40	pSec	
RMS Phase Jitter (integrated 12kHz to 20MHz)	-	1	-	1	-	1	pSec	
Aging(@25 1st year)	-	±3	-	±3	-	±3	ppm	
Storage Temp. Range	-55	125	-55	125	-55	125	°C	

Standard frequencies are frequencies which the crystal has been designed and does not imply a stock position.
 .+ Transition times are measured between 10% and 90% of VDD, with an output load of 15pF.

Dimension(mm)

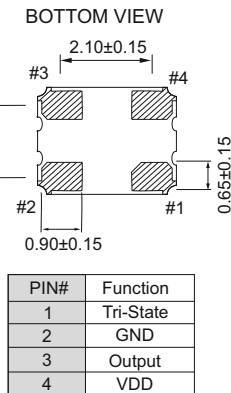
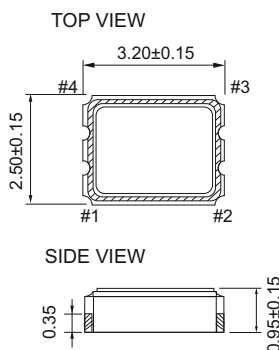

Solder Pad Layout(mm)

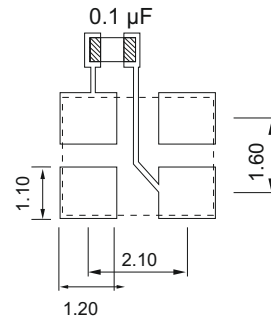

To ensure optimal oscillator performance, place a by-pass capacitor of 0.1 µF as close to the part as possible between Vdd and GND pads.

FREQ. STABILITY vs. TEMP. RANGE

Temp. (°C)	ppm			
	±30	±40	±50	±100
-40 ~ +85	○	○	○	○
-40 ~ +105	△	○	○	○
-40 ~ +125	X	△	○	○
-55 ~ +125	X	X	△	○

○: Available △: Conditional X: Not available
 Inclusive of calibration @ 25 °C, operating temperature range, input voltage variation, load variation, aging (1st year), shock, and vibration

2.5 × 2.0 mm Ultra Low Noise SMD Crystal Oscillator

Feature

- Typical 2.5 x 2.0 x 0.81 mm SMD package.
- Ultra Low Phase Noise designed specifically for Hi-Resolution Audio (HiFi, HD Audio)
- F=45.1584MHz(@1.8V,25°C): typical low close-in phase noise of -100dBc/Hz@10Hz-offset, -127dBc/Hz@100Hz-offset, and a noise floor of -157dBc/Hz
- F=49.152MHz(@1.8V,25°C): typical low close-in phase noise of -100dBc/Hz@10Hz-offset, -128dBc/Hz@100Hz-offset, and a noise floor of -157dBc/Hz
- Wide operating temperature range: -40°C~+105°C

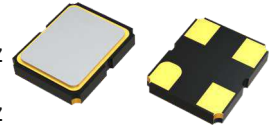

Electrical Specifications

Parameter	3.3V		2.5V		1.8V		Unit	
	Min.	Max.	Min.	Max.	Min.	Max.		
Supply Voltage Variation	2.97	3.63	2.25	2.75	1.62	1.98	V	
Frequency Range	20	60	20	60	20	60	MHz	
Supply Current	-	8	-	7	-	5	mA	
Duty Cycle	45	55	45	55	45	55	%	
Transition Time : Rise/Fall Time	-	6	-	6	-	6	nSec	
Output Level (CMOS)	Out High (Logic "1")	2.97	2.25	1.62			V	
	Out Low (Logic "0")		0.33	0.25	0.18			
Start Time	-	2	-	2	-	2	mSec	
Tri-State (Input to Pin 1)	Enable (High Voltage or floating)	2.31	-	1.75	-	1.26	V	
	Disable (Low Voltage or GND)	-	0.99	-	0.75	-		0.54
RMS Phase Jitter (Integrated 12kHz to 20MHz)	-	0.5	-	0.5	-	0.5	pSec	
Phase Noise (TYP.)		F=20MHz		F=40MHz		F=60MHz		dBc/Hz
1.8V, 25°C	1kHz offset	-147		-143		-139		
	100kHz offset	-156		-154		-150		
2.5 to 3.3V, 25°C	1kHz offset	-151		-148		-142		
	100kHz offset	-157		-156		-156		
Aging (@25°C 1st year)	-	±3	-	±3	-	±3	ppm	
Storage Temp. Range	-55	125	-55	125	-55	125	°C	

Standard frequencies are frequencies which the crystal has been designed and does not imply a stock position
 .+ Transition times are measured between 10% and 90% of VDD, with an output load of 15pF.

Dimension(mm)

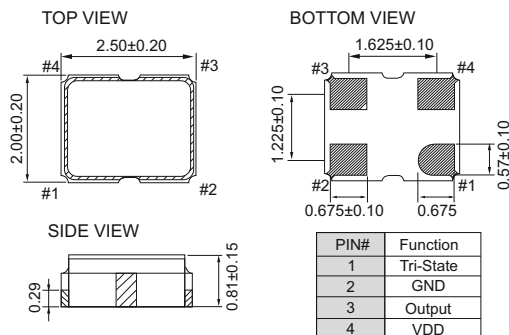

Solder Pad Layout(mm)

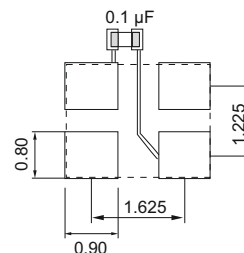

To ensure optimal oscillator performance, place a by-pass capacitor of 0.1 µF as close to the part as possible between Vdd and GND pads.

FREQ. STABILITY vs. TEMP. RANGE

Temp. (°C)	ppm			
	±20	±25	±30	±50
-10 ~ +60	○	○	○	○
-20 ~ +70	△	○	○	○
-40 ~ +85	X	○	○	○
-40 ~ +105	X	X	△	○

○: Available △: Conditional X: Not available
 Inclusive of calibration @ 25 °C, operating temperature range, input voltage variation, load variation, aging (1st year), shock, and vibration

3.2 × 2.5 mm Ultra Low Noise SMD Crystal Oscillator

Feature

- Typical 3.2 x 2.5 x 0.95 mm SMD package.
- Ultra Low Phase Noise designed specifically for Hi-Resolution Audio (HiFi , HD Audio)
- F=45.1584MHz(@1.8V,25°C):typical low close-in phase noise of-100dBc/Hz@10Hz-offset, -127dBc/Hz@100Hz-offset,and a noise floor of-157dBc/Hz
- F=49.152MHz(@1.8V,25°C):typical low close-in phase noise of-100dBc/Hz@10Hz-offset, -128dBc/Hz@100Hz-offset,and a noise floor of-157dBc/Hz
- Wide operating emperature range:-40°C~+105°C

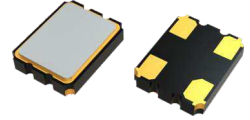

Electrical Specifications

Parameter	3.3V		2.5V		1.8V		Unit
	Min.	Max.	Min.	Max.	Min.	Max.	
Supply Voltage Variation	2.97	3.63	2.25	2.75	1.62	1.98	V
Frequency Range	20	60	20	60	20	60	MHz
Supply Current	-	8	-	7	-	5	mA
Duty Cycle	45	55	45	55	45	55	%
Transition Time :Rise/Fall Time	-	6	-	6	-	6	nSec
Output Level (CMOS)	Out High(Logic"1")	2.97	2.25	1.62			V
	Out Low(Logic"0")		0.33	0.25	0.18		
Start Time	-	2	-	2	-	2	mSec
Tri-State (Input to Pin 1)	Enable(High Voltage or floating)	2.31	-	1.75	-	1.26	V
	Disable(Low Voltage or GND)	-	0.99	-	0.75	-	
RMS Phase Jitter (Integrated 12kHz to 20MHz)	-	0.5	-	0.5	-	0.5	pSec
Phase Noise (TYP.)	F=20MHz		F=40MHz		F=60MHz		dBc/Hz
1.8V, 25°C	1kHz offset	-147	-143	-139			dBc/Hz
	100kHz offset	-156	-154	-150			dBc/Hz
2.5 to 3.3V, 25°C	1kHz offset	-151	-148	-142			dBc/Hz
	100kHz offset	-157	-156	-156			dBc/Hz
Aging(@25°C 1st year)	-	±3	-	±3	-	±3	ppm
Storage Temp. Range	-55	125	-55	125	-55	125	°C

Standard frequencies are frequencies which the crystal has been designed and does not imply a stock position
 .+ Transition times are measured between 10% and 90% of VDD, with an output load of 15pF.

Dimension(mm)

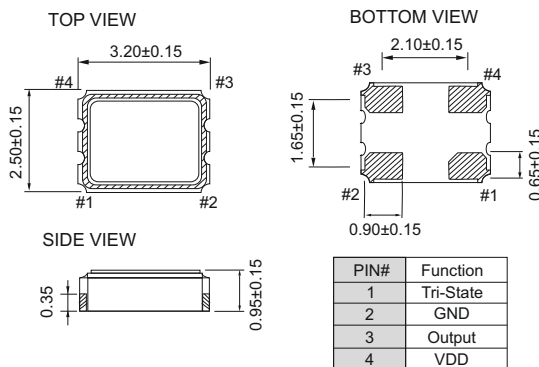

Solder Pad Layout(mm)

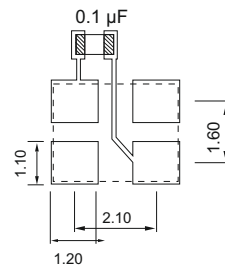

To ensure optimal oscillator performance, place a by-pass capacitor of 0.1 µF as close to the part as possible between Vdd and GND pads.

FREQ. STABILITY vs. TEMP. RANGE

Temp. (°C) \ ppm	±20	±25	±30	±50
-10 ~ +60	o	o	o	o
-20 ~ +70	Δ	o	o	o
-40 ~ +85	X	o	o	o
-40 ~ +105	X	X	Δ	o

o: Available Δ:Conditional X: Not available
 Inclusive of calibration @ 25 °C, operating temperature range, input voltage variation, load variation, aging (1st year), shock, and vibration

20.8 x 12.46 DIP14 FULL Size Crystal Oscillator

Feature

- Typical 20.8 x12.46 x5 mm
- Tight symmetry (45 to 55%) available.
- Operation voltage: 5V, 3.3V
- Tri-state enable/disable



Electrical Specifications

Parameter		3.3V		5.0V		Unit
		Min.	Max.	Min.	Max.	
Fan out Type		CMOS		TTL/CMOS		
Supply Voltage Variation		3.0	3.6	4.5	5.5	V
Frequency Range		0.25	180	0.25	180	MHz
Frequency Stability		±25, ±50, ±100 or specify				PPM
Operating Temperature		0~70,-20~70, -40~85 or specify				°C
Supply Current	0.25 MHz ≦ FO<20MHz	-	10	-	15	mA
	20 MHz ≦ FO<50MHz	-	30	-	40	mA
	50 MHz ≦ FO<180MHz	-	40	-	50	mA
Duty Cycle		45	55	45	55	%
Transition Time : Rise/Fall Time	0.25 MHz ≦ FO<20MHz	-	10	-	8	nSec
	20 MHz ≦ FO<50MHz	-	6	-	5	
	50 MHz ≦ FO<180MHz	-	5	-	4	
Input Voltage	Vol (Max)	-	0.33	-	0.4/0.5	V
	2.4V/4.5V	2.4/2.5	-	3.0	-	
Driving Ability	CMOS load max	15		15/50		pF
	TTL load max			10TTL		
Start Time		5 ms max(15pF)/ 10 ms (50pF)				mSec
E/D Function	#1 OPEN	Pin#8 Open		Pin#8 Open		
	#1 >=2.2V	Pin#8 Open		Pin#8 Open		
	#1 <=0.8V	Pin#8 High		Pin#8 High		
Aging(@25°C 1st year)		±3	±5	±3	±5	ppm
Storage Temp. Range		-55	125	-55	125	°C

Dimension(mm)

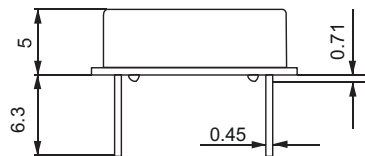
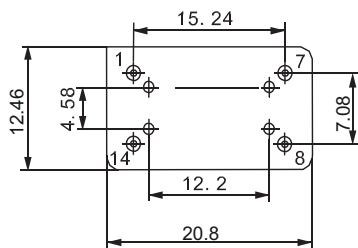

Pin	Function
1	Tri-State/NC
7	GND
8	Output
14	Vdd

12.46 x 12.46 DIP8 Half Size Crystal Oscillator

Feature

- Typical 12.46 x12.46x5 mm
- Tight symmetry (45 to 55%) available.
- Operation voltage:5V, 3.3V
- Tri-state enable/disable



Electrical Specifications

Parameter	3.3V		5.0V		Unit	
	Min.	Max.	Min.	Max.		
Fan out Type	CMOS		TTL/CMOS			
Supply Voltage Variation	3.0	3.6	4.5	5.5	V	
Frequency Range	0.25	180	0.25	180	MHz	
Frequency Stability	±25, ±50, ±100				PPM	
Operating Temperature	0~70,-20~70,-40~85				°C	
Supply Current	0.25 MHz ≡ FO<20MHz	-	10	-	15	mA
	20 MHz ≡ FO<50MHz	-	30	-	40	mA
	50 MHz ≡ FO<180MHz	-	40	-	50	mA
Duty Cycle	45	55	45	55	%	
Transition Time : Rise/Fall Time	0.25 MHz ≡ FO<20MHz	-	10	-	8	nSec
	20 MHz ≡ FO<50MHz	-	6	-	5	
	50 MHz ≡ FO<180MHz	-	5	-	4	
Input Voltage	Vol (Max)	-	0.33	-	0.4/0.5	V
	2.4V/4.5V	2.4/2.5	-	3.0	-	
Driving Ability	CMOS load max	15		15/50		pF
	TTL load max			10TTL		
Start Time	5 ms max(15pF)/ 10 ms (50pF)				mSec	
E/D Function	#1 OPEN	Pin#5 Open		Pin#5 Open		
	#1 >=2.2V	Pin#5 Open		Pin#5 Open		
	#1 <=0.8V	Pin#5 High		Pin#5 High		
Aging(@25°C 1st year)	±3	±5	±3	±5	ppm	
Storage Temp. Range	-55	125	-55	125	°C	

Dimension(mm)

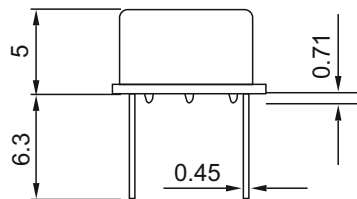
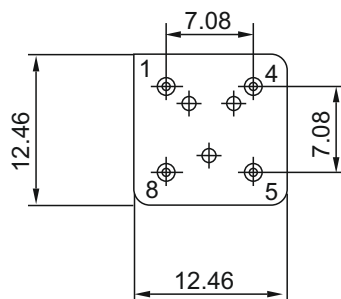

Pin	Function
1	Tri-State/NC
4	GND
5	Output
8	Vdd

FASTXO 2.0 x 1.6 mm SMD Crystal Oscillator

Feature

- Typical 2.05 x 1.65 x 0.75 mm ceramic SMD package
- Operation supply voltage: 1.8V, 2.5V and 3.3V
- FASTXO series, Fast delivery at any frequency
- Tri-State Enable/Disable
- Frequency Stability ± 25 ppm over -40 °C to 85 °C
- RoHS compliant/Pb-free

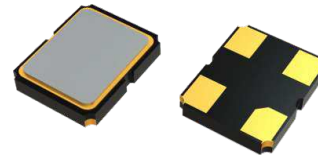

Electrical Specifications

Parameter	3.3V		2.5V		1.8V		Unit
	Min.	Max.	Min.	Max.	Min.	Max.	
Supply Voltage Variation	$V_{DD}-5\%$	$V_{DD}+5\%$	$V_{DD}-5\%$	$V_{DD}+5\%$	$V_{DD}-5\%$	$V_{DD}+5\%$	V
Frequency Range	1	200	1	200	1	125	MHz
Supply Current	-	30	-	28	-	20	mA
Duty Cycle	45	55	45	55	45	55	%
Output Level (CMOS)	Out High (Logic "1")	2.97	-	2.25	-	1.62	V
	Out Low (Logic "0")	-	0.33	-	0.25	-	
Start Time	-	8	-	8	-	8	mSec
Transition Time : Rise/Fall Time	-	2	-	2	-	3	nSec
Tri-State	Output Enable	2.31	-	1.75	-	1.26	V
	Output Disable	-	0.99	-	0.75	-	
Stand by current (@PD mode)	-	400	-	400	-	400	uA
Stand by current (@OE mode)	-	20	-	20	-	20	mA
Output Loading Jitter (12KHz)	15		15		15		
RMS Phase Jiter (12KHz to 20MHz) @ 3.3V	-	1	-	1	-	1	pSec
Aging (@ 25 1st year)	-	± 3	-	± 3	-	± 3	ppm
Storage Temp. Range	-55	125	-55	125	-55	125	°C

Standard frequencies are frequencies which the crystal has been designed and does not imply a stock position.

+ Transition times are measured between 10% and 90% of VDD, with an output load of 15pF.

Dimension(mm)

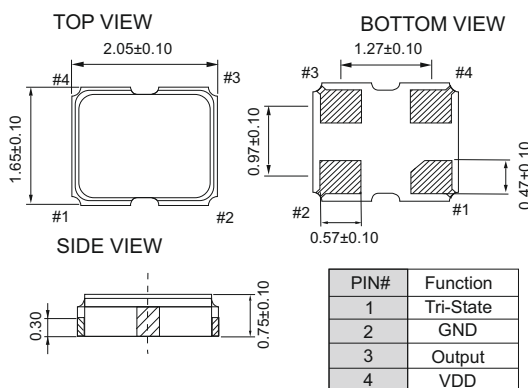

Solder Pad Layout(mm)

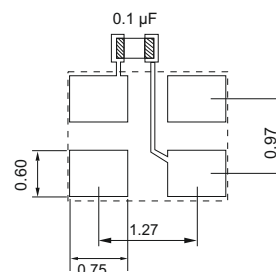

To ensure optimal oscillator performance, place a by-pass capacitor of 0.1 μ F as close to the part as possible between Vdd and GND pads.

FREQ. STABILITY vs. TEMP. RANGE

Temp. (°C)	ppm ± 15	ppm ± 20	ppm ± 25	ppm ± 50
-20 ~ +70	o	o	o	o
-40 ~ +85	x	Δ	o	o
-40 ~ +105	x	x	Δ	o

o: Available Δ : Conditional X: Not available

Inclusive of calibration @ 25 °C, operating temperature range, input voltage variation, load variation, aging (1st year), shock, and vibration

FASTXO 2.5 × 2.0 mm SMD Crystal Oscillator

Feature

- Typical 2.5 x 2.0 x 0.81 mm ceramic SMD package.
- Operation supply voltage: 1.8V, 2.5V and 3.3V
- FASTXO series, Fast delivery at any frequency
- Tri-State Enable/Disable
- Frequency Stability ±25ppm over -40 °C to 85 °C
- RoHS compliant/Pb-free

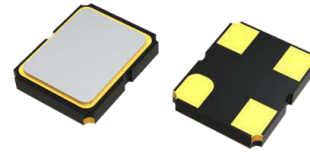

Electrical Specifications

Parameter	3.3V		2.5V		1.8V		Unit	
	Min.	Max.	Min.	Max.	Min.	Max.		
Supply Voltage Variation	V _{DD} -5%	V _{DD} +5%	V _{DD} -5%	V _{DD} +5%	V _{DD} -5%	V _{DD} +5%	V	
Frequency Range	1	200	1	200	1	125	MHz	
Supply Current	-	30	-	28	-	20	mA	
Duty Cycle	45	55	45	55	45	55	%	
Output Level (CMOS)	Out High (Logic "1")	2.97	-	2.25	-	1.62	-	V
	Out Low (Logic "0")	-	0.33	-	0.25	-	0.18	
Start Time	-	8	-	8	-	8	mSec	
Transition Time : Rise/Fall Time	-	2	-	2	-	3	nSec	
Tri-State	Output Enable	2.31	-	1.75	-	1.26	-	V
	Output Disable	-	0.99	-	0.75	-	0.54	
Stand by current (@PD mode)	-	400	-	400	-	400	uA	
Stand by current (@OE mode)	-	20	-	20	-	20	mA	
Output Loading	15		15		15			
RMS Phase Jitter (12kHz to 20MHz) @ 3.3V	-	1	-	1	-	1	pSec	
Aging (@25 1st year)	-	±3	-	±3	-	±3	ppm	
Storage Temp. Range	-55	125	-55	125	-55	125	°C	

Standard frequencies are frequencies which the crystal has been designed and does not imply a stock position.

+ Transition times are measured between 10% and 90% of V_{DD}, with an output load of 15pF.

Dimension (mm)

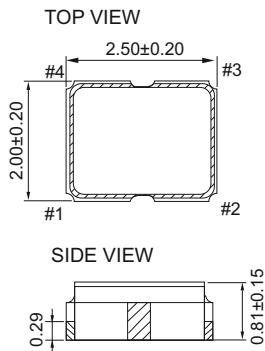

PIN#	Function
1	Tri-State
2	GND
3	Output
4	VDD

Solder Pad Layout (mm)

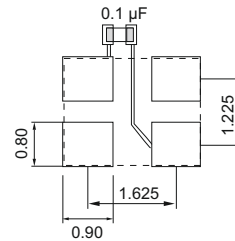

To ensure optimal oscillator performance, place a by-pass capacitor of 0.1 µF as close to the part as possible between V_{DD} and GND pads.

FREQ. STABILITY vs. TEMP. RANGE

Temp. (°C) \ ppm	±15	±20	±25	±50
-20 ~ +70	Δ	○	○	○
-40 ~ +85	X	Δ	○	○
-40 ~ +105	X	X	Δ	○

○: Available Δ: Conditional X: Not available

Inclusive of calibration @ 25 °C, operating temperature range, input voltage variation, load variation, aging (1st year), shock, and vibration

FASTXO 3.2 × 2.5 mm SMD Crystal Oscillator

Feature

- Typical 3.2 x 2.5 x 0.95 mm ceramic SMD package.
- Operation supply voltage: 1.8V, 2.5V and 3.3V
- FASTXO series, Fast delivery at any frequency
- Tri-State Enable/Disable
- Frequency Stability ± 25 ppm over -40 °C to 85 °C
- RoHS compliant/Pb-free

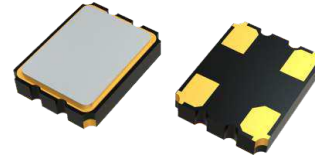

Electrical Specifications

Parameter	3.3V		2.5V		1.8V		Unit
	Min.	Max.	Min.	Max.	Min.	Max.	
Supply Voltage Variation	$V_{DD}-5\%$	$V_{DD}+5\%$	$V_{DD}-5\%$	$V_{DD}+5\%$	$V_{DD}-5\%$	$V_{DD}+5\%$	V
Frequency Range	1	200	1	200	1	125	MHz
Supply Current	-	30	-	28	-	20	mA
Duty Cycle	45	55	45	55	45	55	%
Output Level (CMOS)	Out High(Logic"1")	2.97	-	2.25	-	1.62	V
	Out Low(Logic"0")	-	0.33	-	0.25	-	
Start Time	-	8	-	8	-	8	mSec
Transition Time :Rise/Fall Time	-	2	-	2	-	3	nSec
Tri-State	Output Enable	2.31	-	1.75	-	1.26	V
	Output Disable	-	0.99	-	0.75	-	
Stand by current(@PD mode)	-	400	-	400	-	400	uA
Stand by current(@OE mode)	-	20	-	20	-	20	mA
Output Loading	15		15		15		
RMS Phase Jiter(12kHz to 20MHz)@3.3V	-	1	-	1	-	1	pSec
Aging(@25 1st year)	-	± 3	-	± 3	-	± 3	ppm
Storage Temp. Range	-55	125	-55	125	-55	125	°C

Standard frequencies are frequencies which the crystal has been designed and does not imply a stock position.

+ Transition times are measured between 10% and 90% of VDD, with an output load of 15pF.

Dimension(mm)

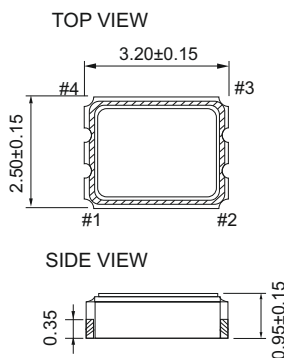

PIN#	Function
1	Tri-State
2	GND
3	Output
4	VDD

Solder Pad Layout(mm)

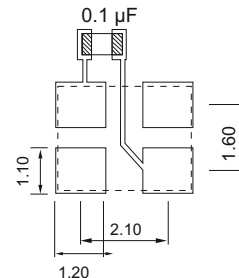

To ensure optimal oscillator performance, place a by-pass capacitor of 0.1 µF as close to the part as possible between Vdd and GND pads.

FREQ. STABILITY vs. TEMP. RANGE

Temp. (°C)	ppm			
	±15	±20	±25	±50
-20 ~ +70	o	o	o	o
-40 ~ +85	x	Δ	o	o
-40 ~ +105	x	x	Δ	o

o: Available Δ: Conditional X: Not available

Inclusive of calibration @ 25 °C, operating temperature range, input voltage variation, load variation, aging (1st year), shock, and vibration

FASTXO 5.0 × 3.2 mm SMD Crystal Oscillator

Feature

- Typical 5.0 x 3.2 x 1.2 mm ceramic SMD package.
- Operation supply voltage: 1.8V, 2.5V and 3.3V
- FASTXO series, Fast delivery at any frequency
- Tri-State Enable/Disable
- Frequency Stability ±25ppm over -40 °C to 85 °C
- RoHS compliant/Pb-free

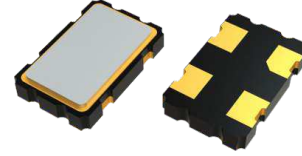

Electrical Specifications

Parameter	3.3V		2.5V		1.8V		Unit
	Min.	Max.	Min.	Max.	Min.	Max.	
Supply Voltage Variation	V _{DD} -5%	V _{DD} +5%	V _{DD} -5%	V _{DD} +5%	V _{DD} -5%	V _{DD} +5%	V
Frequency Range	1	200	1	200	1	125	MHz
Supply Current	-	30	-	28	-	20	mA
Duty Cycle	45	55	45	55	45	55	%
Output Level (CMOS)	Out High(Logic"1")	2.97	-	2.25	-	1.62	V
	Out Low(Logic"0")	-	0.33	-	0.25	-	
Start Time	-	8	-	8	-	8	mSec
Transition Time :Rise/Fall Time	-	2	-	2	-	3	nSec
Tri-State	Output Enable	2.31	-	1.75	-	1.26	V
	Output Disable	-	0.99	-	0.75	-	
Stand by current(@PD mode)	-	400	-	400	-	400	uA
Stand by current(@OE mode)	-	20	-	20	-	20	mA
Output Loading	15		15		15		
RMS Phase Jiter(12kHz to 20MHz)@3.3V	-	1	-	1	-	1	pSec
Aging(@25 1st year)	-	±3	-	±3	-	±3	ppm
Storage Temp. Range	-55	125	-55	125	-55	125	°C

Standard frequencies are frequencies which the crystal has been designed and does not imply a stock position.
+ Transition times are measured between 10% and 90% of VDD, with an output load of 15pF.

Dimension(mm)

TOP VIEW

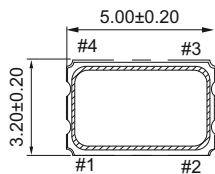

BOTTOM VIEW

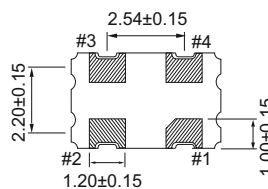

SIDE VIEW

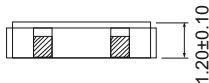

PIN#	Function
1	Tri-State
2	GND
3	Output
4	VDD

Solder Pad Layout(mm)

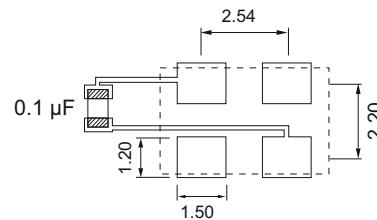

To ensure optimal oscillator performance, place a by-pass capacitor of 0.1 µF as close to the part as possible between Vdd and GND pads.

FREQ. STABILITY vs. TEMP. RANGE

ppm / Temp. (°C)	±15	±20	±25	±50
-20 ~ +70	o	o	o	o
-40 ~ +85	X	Δ	o	o
-40 ~ +105	X	X	Δ	o

o: Available Δ: Conditional X: Not available
Inclusive of calibration @ 25 °C, operating temperature range, input voltage variation, load variation, aging (1st year), shock, and vibration

FASTXO 7.0 × 5.0 mm SMD Crystal Oscillator

Feature

- Typical 7.0 x 5.0 x1.3 mm ceramic SMD package
- Operation supply voltage: 1.8V, 2.5V and 3.3V
- FASTXO series, Fast delivery at any frequency
- Tri-State Enable/Disable
- Frequency Stability ±25ppm over -40 °C to 85 °C
- RoHS compliant/Pb-free

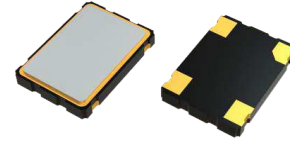

Electrical Specifications

Parameter	3.3V		2.5V		1.8V		Unit
	Min.	Max.	Min.	Max.	Min.	Max.	
Supply Voltage Variation	V _{DD} -5%	V _{DD} +5%	V _{DD} -5%	V _{DD} +5%	V _{DD} -5%	V _{DD} +5%	V
Frequency Range	1	200	1	200	1	125	MHz
Supply Current	-	30	-	28	-	20	mA
Duty Cycle	45	55	45	55	45	55	%
Output Level (CMOS)	Out High(Logic"1")	2.97	-	2.25	-	1.62	V
	Out Low(Logic"0")	-	0.33	-	0.25	-	
Start Time	-	8	-	8	-	8	mSec
Transition Time :Rise/Fall Time	-	2	-	2	-	3	nSec
Tri-State	Output Enable	2.31	-	1.75	-	1.26	V
	Output Disable	-	0.99	-	0.75	-	
Stand by current(@PD mode)	-	400	-	400	-	400	uA
Stand by current(@OE mode)	-	20	-	20	-	20	mA
Output Loading	15		15		15		
RMS Phase Jiter(12kHz to 20MHz)@3.3V	-	1	-	1	-	1	pSec
Aging(@25 1st year)	-	±3	-	±3	-	±3	ppm
Storage Temp.Range	-55	125	-55	125	-55	125	°C

Standard frequencies are frequencies which the crystal has been designed and does not imply a stock position.
+ Transition times are measured between 10% and 90% of VDD, with an output load of 15pF.

Dimension(mm)

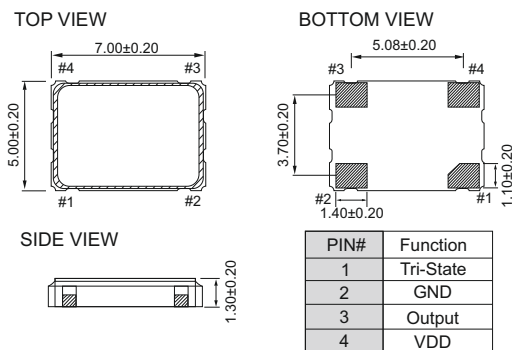

Solder Pad Layout(mm)

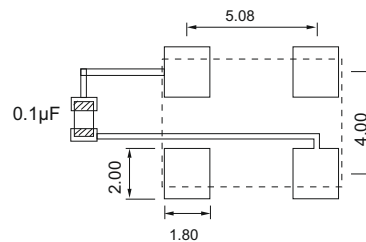

To ensure optimal oscillator performance, place a by-pass capacitor of 0.1 µF as close to the part as possible between Vdd and GND pads.

FREQ. STABILITY vs. TEMP. RANGE

Temp. (°C) \ ppm	±15	±20	±25	±50
-20 ~ +70	○	○	○	○
-40 ~ +85	x	△	○	○
-40 ~ +105	x	x	△	○

○: Available △: Conditional X: Not available
Inclusive of calibration @ 25 °C, operating temperature range, input voltage variation, load variation, aging (1st year), shock, and vibration

FASTXO 3.2 × 2.5 mm SMD CMOS Output Crystal Oscillator

Feature

- Low power supply voltage: 3.3, 2.5 supply options
- Singled-end output : CMOS
- Frequency support from 10MHz to 250MHz
- Low noise typical: 0.8 ps at 12kHz to 20MHz frequency offsets
- Temperature range: -40 to 85 °C operation
- Fast delivery

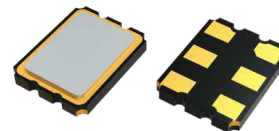

Electrical Specifications

Parameter	3.3V		2.5V		Unit
	Min.	Max.	Min.	Max.	
Supply Voltage Variation	2.97	3.63	2.375	2.625	V
Frequency Range	10	250	10	250	MHz
Supply Current	-	50	-	45	mA
Output level	Output High	2.97	-	2.25	V
	Output Low	-	0.33	-	
Transition Time : Rise/Fall Time	-	1.0	-	1.0	nSec
Start Time	-	10	-	10	mSec
Tri-State(Input to Pin 1/2)	Enable	2.31	-	1.75	V
	Disable	-	0.99	-	
Stand by current	-	18	-	18	mA
Output Loading (10MHz to 200MHz)	-	15	-	15	pF
Output Loading (200MHz to 250MHz)	-	5	-	5	pF
RMS Phase Jiter(integrated 12kHz ~ 20MHz)	0.8	1.5	0.8	1.5	pSec
Phase Noise @125MHz	1kHz	-107	-107	-107	dBc/Hz
	10kHz	-111	-111	-111	
	100kHz	-114	-114	-114	
	1MHz	-125	-125	-125	
	20MHz	-147	-147	-147	
Aging(@25 1st year)	-	±3	-	±3	ppm
Storage Temp. Range	-55	125	-55	125	°C

.+ Transition times are measured between 20% and 80% of VDD.

Dimension(mm)

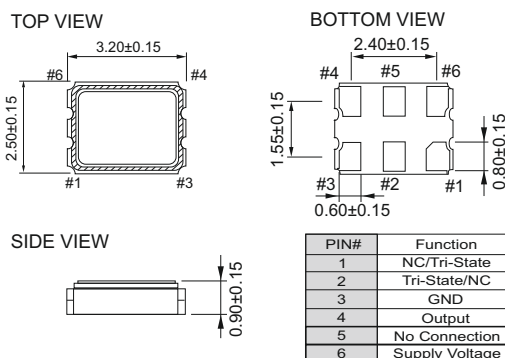

Solder Pad Layout(mm)

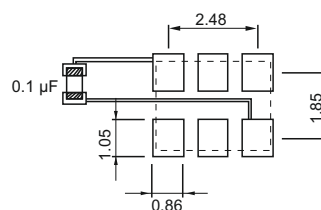

To ensure optimal oscillator performance, place a by-pass capacitor of 0.1 µF as close to the part as possible between Vdd and GND pads.

FREQ. STABILITY vs. TEMP. RANGE

Temp. (°C)	ppm	
	±25	±50
-10 ~ +60	o	o
-20 ~ +70	o	o
-40 ~ +85	Δ	o

o: Available Δ: Conditional X: Not available
Inclusive of calibration @ 25 °C, operating temperature range, input voltage variation, load variation, aging (1st year), shock, and vibration

FASTXO 5.0 × 3.2 mm SMD CMOS Crystal Oscillator

Feature

- Typical 5.0 x 3.2 ceramic SMD package
- Very low phase jitter : < 1 ps (0.6ps, typ.) RMS
- Any frequency between 10 MHz and 250 MHz
- Tri-state enable/disable
- Fast delivery

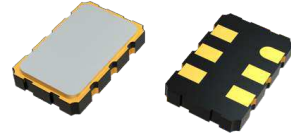

Electrical Specifications

Parameter	CMOS				Unit
	3.3V		2.5V		
	Min.	Max.	Min.	Max.	
Supply Voltage Variation	3.135	3.465	2.375	2.625	V
Frequency Range	10	250	10	250	MHz
Standard Frequency	106.25,125,133.33,150,155.52,156.25, 212.5				MHz
Supply Current 10 MHz ≤ FO < 250MHz	-	30	-	30	mA
Output level	Output High	2.97	-	2.25	V
	Output Low	-	0.33	-	
Transition Time : Rise/Fall Time	-	1.5	-	1.5	nSec
Start Time	-	10	-	10	mSec
Tri-State (Input to Pin 1/2)	Enable	2.31	-	1.75	V
	Disable	-	0.99	-	
RMS Phase Jitter(integrated 12kHz ~ 20MHz)	1.0		1.0		pSec
Phase Noise @125MHz	100Hz	-75		-75	dBc/Hz
	1kHz	-105		-105	
	10kHz	-120		-120	
Aging(@25 1st year)	-	±3	-	±3	ppm
Storage Temp. Range	-55	125	-55	125	°C

.+ Transition times are measured between 20% and 80% of VDD.

Dimension(mm)

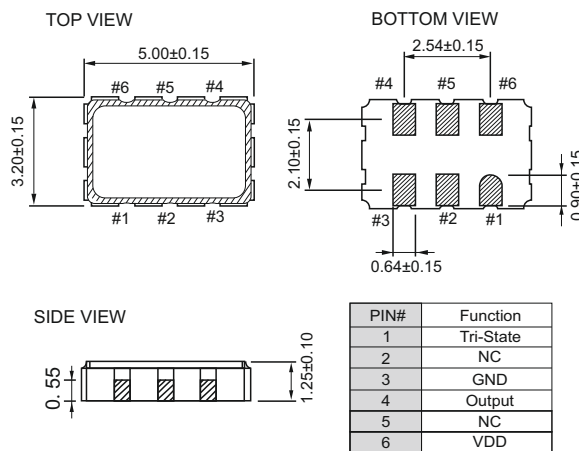

Solder Pad Layout(mm)

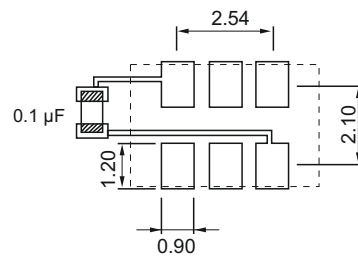

To ensure optimal oscillator performance, place a by-pass capacitor of 0.1 µF as close to the part as possible between Vdd and GND pads.

FREQ. STABILITY vs. TEMP. RANGE

Temp. (°C)	ppm	
	±25	±50
-10 ~ +60	○	○
-20 ~ +70	○	○
-40 ~ +85	△	○

○: Available △: Conditional X: Not available

Inclusive of calibration @ 25 °C, operating temperature range, input voltage variation, load variation, aging (1st year), shock, and vibration

FASTXO 7.0 × 5.0 mm SMD CMOS Crystal Oscillator

Feature

- Typical 7.0 x 5.0 SMD package
- Very low phase jitter : < 1 ps (0.6ps, typ.) RMS
- Any frequency between 10 MHz and 250 MHz
- Tri-state enable/disable
- Fast delivery

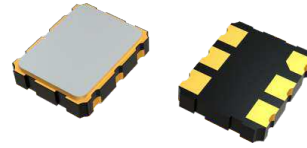

Electrical Specifications

Parameter	CMOS				Unit
	3.3V		2.5V		
	Min.	Max.	Min.	Max.	
Supply Voltage Variation	3.135	3.465	2.375	2.625	V
Frequency Range	10	250	10	250	MHz
Standard Frequency	106.25,125,133.33,150,155.52,156.25,187.5,212.5				MHz
Supply Current 10 MHz ≡ FO<250MHz	-	30	-	30	mA
Output level	Output High	2.97	-	2.25	V
	Output Low	-	0.33	-	
Transition Time : Rise/Fall Time	-	1.5	-	1.5	nSec
Start Time	-	10	-	10	mSec
Tri-State (Input to Pin 1/2)	Enable	2.31	-	1.75	V
	Disable	-	0.99	-	
RMS Phase Jitter(integrated 12kHz ~ 20MHz)	-	1	-	1	pSec
Phase Noise @125MHz	100Hz	-75		-75	dBc/Hz
	1kHz	-105		-105	
	10kHz	-120		-120	
Aging(@25 1st year)	-	±3	-	±3	ppm
Storage Temp. Range	-55	125	-55	125	°C

.+ Transition times are measured between 20% and 80% of VDD.

Dimension(mm)

TOP VIEW

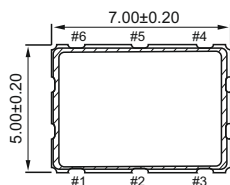

BOTTOM VIEW

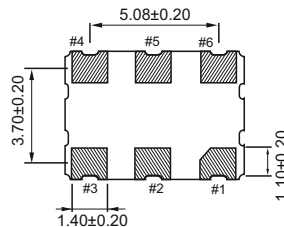

Solder Pad Layout(mm)

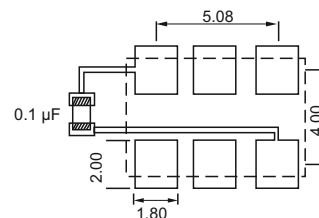

SIDE VIEW

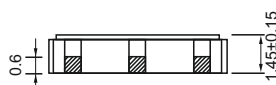

PIN#	Function
1	NC/Tri-State
2	Tri-State/NC
3	GND
4	Output
5	Comp Output
6	VDD

To ensure optimal oscillator performance, place a by-pass capacitor of 0.1 µF as close to the part as possible between Vdd and GND pads.

FREQ. STABILITY vs. TEMP. RANGE

Temp. (°C) \ ppm	±25	±50
-10 ~ +60	○	○
-20 ~ +70	○	○
-40 ~ +85	△	○

○: Available △: Conditional X: Not available

Inclusive of calibration @ 25 °C, operating temperature range, input voltage variation, load variation, aging (1st year), shock, and vibration

3.2 × 2.5mm SMD Differential Output Oscillator

Feature

- Low power supply voltage: 3.3, 2.5 supply options
- Differential output :VPECL, LVDS
- Frequency support from 10MHz to 1.5GHz
- Low noise typical: 0.8 ps at 12kHz to 20MHz frequency offsets
- Temperature range: -40 to 85 °C operation
- Fast delivery

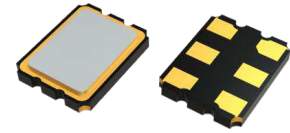

Electrical Specifications

Parameter	LVPECL				LVDS				Unit	
	3.3V		2.5V		3.3V		2.5V			
	Min.	Max.	Min.	Max.	Min.	Max.	Min.	Max.		
Supply Voltage Variation	3.135	3.465	2.375	2.625	3.135	3.465	2.375	2.625	V	
Frequency Range	10	1500	10	1500	10	1500	10	1500	MHz	
Supply Current	-	50	-	50	-	50	-	50	mA	
Output level	Output High	2.275	2.7	1.475	1.9	-	1.6	-	1.6	V
	Output Low	1.45	1.68	0.65	0.88	0.9	-	0.9	-	
Transition Time : Rise/Fall Time	-	1.0	-	1.0	-	1.0	-	1.0	nSec	
Start Time	-	10	-	10	-	10	-	10	mSec	
Tri-State (Input to Pin 1/2)	Enable	2.31	-	1.75	-	2.31	-	1.75	-	V
	Disable	-	0.99	-	0.75	-	0.99	-	0.75	
RMS Phase Jitter(integrated 12kHz ~ 20MHz)	-	1.5	-	1.5	-	1.5	-	1.5	pSec	
Phase Noise @250MHz VDD=3.3v	1kHz	-107	-107	-107	-107	-107	-107	-107	dBc/Hz	
	10kHz	-111	-111	-111	-111	-111	-111	-111		
	100kHz	-114	-114	-114	-114	-114	-114	-114		
	1MHz	-125	-125	-125	-125	-125	-125	-125		
	20MHz	-147	-147	-147	-147	-147	-147	-147		
Aging(@25 1st year)	-	±3	-	±3	-	±3	-	±3	ppm	
Storage Temp. Range	-55	125	-55	125	-55	125	-55	125	°C	

Dimension(mm)

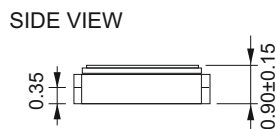
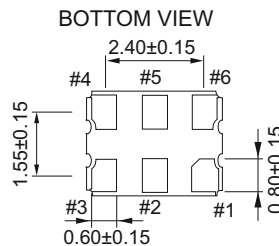
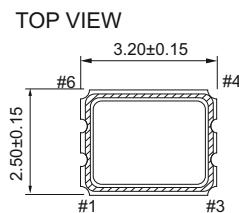

PIN#	Function
1	NC/Tri-State
2	Tri-State/NC
3	GND
4	Output
5	No Connection
6	Supply Voltage

Solder Pad Layout(mm)

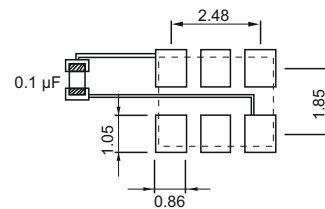

To ensure optimal oscillator performance, place a by-pass capacitor of 0.1 µF as close to the part as possible between Vdd and GND pads.

FREQ. STABILITY vs. TEMP. RANGE

Temp. (°C)	ppm	
	±25	±50
-10 ~ +60	○	○
-20 ~ +70	○	○
-40 ~ +85	△	○

○: Available △: Conditional X: Not available
 Inclusive of calibration @ 25 °C, operating temperature range, input voltage variation, load variation, aging (1st year), shock, and vibration

5.0 × 3.2mm SMD LVPECL /LVDS Crystal Oscillator

Feature

- Industry Standard 5.0 x 3.2 x 1.25 hermetically sealed package
- Very low phase jitter : < 1 ps (0.6ps, typ.) RMS
- Any frequency between 10 MHz and 1500 MHz
- Tri-state enable/disable
- Fast delivery

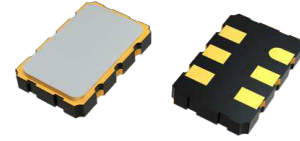

Electrical Specifications

Parameter	LVPECL				LVDS				Unit	
	3.3V		2.5V		3.3V		2.5V			
	Min.	Max.	Min.	Max.	Min.	Max.	Min.	Max.		
Supply Voltage Variation	3.135	3.465	2.375	2.625	3.135	3.465	2.375	2.625	V	
Frequency Range	10	1500	10	1500	10	1500	10	1500	MHz	
Standard Frequency	106.25,125,133.33,150,155.52,156.25,187.5,212.5,312.5,622.08								MHz	
Supply Current 10 MHz ≤ FO < 1500MHz	-	50	-	50	-	50	-	50	mA	
Output level	Output High	2.275	-	1.475	-	1.6	-	1.6	V	
	Output Low	-	1.68	-	0.88	0.9	-	0.9		
Transition Time : Rise/Fall Time	-	1.0	-	1.0	-	1.0	-	1.0	nSec	
Start Time	-	10	-	10	-	10	-	10	mSec	
Tri-State (Input to Pin 1/2)	Enable	2.31	-	1.75	-	2.31	-	1.75	V	
	Disable	-	0.99	-	0.75	-	0.99	-		0.75
RMS Phase Jitter (integrated 12kHz ~ 20MHz)	-	1	-	1	-	1	-	1	pSec	
Phase Noise @156.25MHz	100Hz	-85		-85		-85		-85		dBc/Hz
	1kHz	-105		-105		-105		-105		
	10kHz	-115		-115		-115		-115		
Aging (@25 1st year)	-	±3	-	±3	-	±3	-	±3	ppm	
Storage Temp. Range	-55	125	-55	125	-55	125	-55	125	°C	

.+ Transition times are measured between 20% and 80% of VDD.

Dimension(mm)

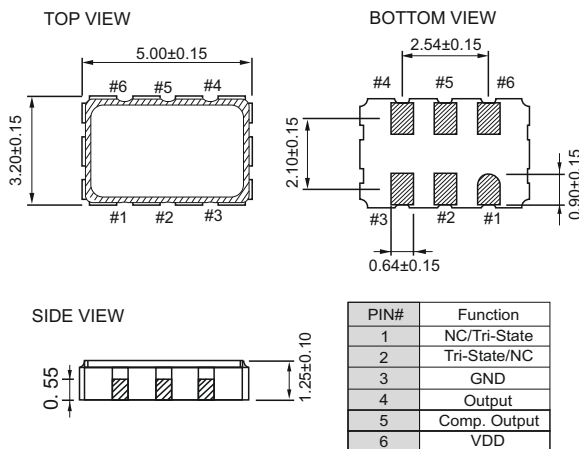

Solder Pad Layout(mm)

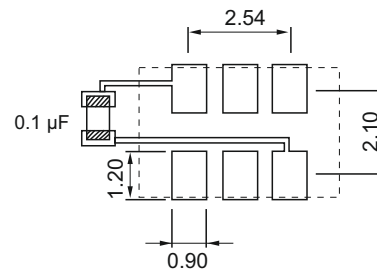

To ensure optimal oscillator performance, place a by-pass capacitor of 0.1 µF as close to the part as possible between Vdd and GND pads.

FREQ. STABILITY vs. TEMP. RANGE

Temp. (°C) \ ppm	±25	±50
-10 ~ +60	○	○
-20 ~ +70	○	○
-40 ~ +85	△	○

○: Available △: Conditional X: Not available

Inclusive of calibration @ 25 °C, operating temperature range, input voltage variation, load variation, aging (1st year), shock, and vibration

7.0 × 5.0 mm SMD LVPECL /LVDS Crystal Oscillator

Feature

- Typical 7.0 x 5.0 x 1.75 ceramic SMD package
- Very low phase jitter : < 1 ps (0.6ps, typ.) RMS
- Any frequency between 10 MHz and 1500 MHz
- Tri-state enable/disable
- Fast delivery

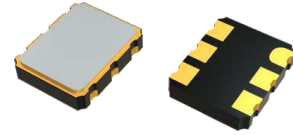

Electrical Specifications

Parameter	LVPECL				LVDS				Unit	
	3.3V		2.5V		3.3V		2.5V			
	Min.	Max.	Min.	Max.	Min.	Max.	Min.	Max.		
Supply Voltage Variation	3.135	3.465	2.375	2.625	3.135	3.465	2.375	2.625	V	
Frequency Range	10	1500	10	1500	10	1500	10	1500	MHz	
Standard Frequency	106.25,125,133.33,150,155.52,156.25,187.5,212.5,312.5,622.08								MHz	
Supply Current 10 MHz ≤ FO < 1500MHz	-	50	-	50	-	50	-	50	mA	
Output level	Output High	2.275	-	1.475	-	-	1.6	-	1.6	V
	Output Low	-	1.68	-	0.88	0.9	-	0.9	-	
Transition Time : Rise/Fall Time	-	1.0	-	1.0	-	1.0	-	1.0	nSec	
Start Time	-	10	-	10	-	10	-	10	mSec	
Tri-State (Input to Pin 1/2)	Enable	2.31	-	1.75	-	2.31	-	1.75	-	V
	Disable	-	0.99	-	0.75	-	0.99	-	0.75	
RMS Phase Jitter(integrated 12kHz ~ 20MHz)	-	1	-	1	-	1	-	1	pSec	
Phase Noise @156.25MHz	100Hz	-94		-94		-94		-94		dBc/Hz
	1kHz	-113		-113		-113		-112		
	10kHz	-122		-122		-122		-122		
Aging(@25 1st year)	-	±3	-	±3	-	±3	-	±3	ppm	
Storage Temp. Range	-55	125	-55	125	-55	125	-55	125	°C	

.+ Transition times are measured between 20% and 80% of VDD.

Dimension(mm)

TOP VIEW

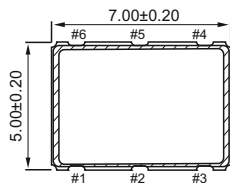

BOTTOM VIEW

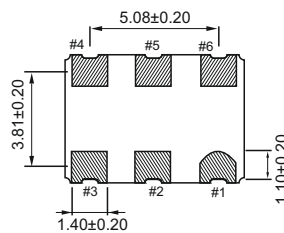

Solder Pad Layout(mm)

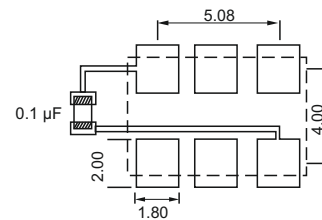

SIDE VIEW

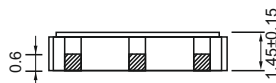

PIN#	Function
1	NC/Tri-State
2	Tri-State/NC
3	GND
4	Output
5	Comp Output
6	VDD

To ensure optimal oscillator performance, place a by-pass capacitor of 0.1 µF as close to the part as possible between Vdd and GND pads.

FREQ. STABILITY vs. TEMP. RANGE

Temp. (°C) \ ppm	±25	±50
-10 ~ +60	○	○
-20 ~ +70	○	○
-40 ~ +85	△	○

○: Available △: Conditional X: Not available
Inclusive of calibration @ 25 °C, operating temperature range, input voltage variation, load variation, aging (1st year), shock, and vibration

3.2 × 2.5 mm SMD LVPECL /LVDS Crystal Oscillator

Feature

- Typical 3.2 x 2.5 x 0.9mm SMD package.
- Very low jitter performance: typical 0.1 pS RMS from 12 kHz-20 MHz
- Fundamental/3rd overtone crystal design
- Output frequency up to 250 MHz
- Tri-state enable/disable
- Up to 125°C operating emperature range

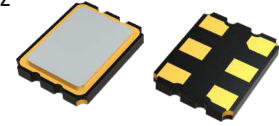

Electrical Specifications

Parameter	LVPECL				LVDS				Unit	
	3.3V		2.5V		3.3V		2.5V			
	Min.	Max.	Min.	Max.	Min.	Max.	Min.	Max.		
Supply Voltage Variation	3.135	3.465	2.375	2.625	3.135	3.465	2.375	2.625	V	
Frequency Range	10	250	10	250	10	250	10	250	MHz	
Standard Frequency	25,106.25,125,156.25,161.1328,212.5								MHz	
Supply Current	10 MHz ≤ FO < 160MHz	-	75	-	75	-	50	-	50	mA
	160 MHz ≤ FO < 250MHz	-	100	-	100	-	50	-	50	
Output level	Output High	2.275	-	1.475	-	-	1.6	-	1.6	V
	Output Low	-	1.68	-	0.88	0.9	-	0.9	-	
Transition Time : Rise/Fall Time	-	1.0	-	1.0	-	1.0	-	1.0	nSec	
Start Time	-	10	-	10	-	10	-	10	mSec	
Tri-State (Input to Pin 1/2)	Enable	2.31	-	1.75	-	2.31	-	1.75	-	V
	Disable	-	0.99	-	0.75	-	0.99	-	0.75	
RMS Phase Jitter (integrated 12kHz ~ 20MHz)	FO < 80MHz	-	1	-	1	-	1	-	1	pSec
	80 MHz ≤ FO < 125MHz	-	0.5	-	0.5	-	0.5	-	0.5	
	125 MHz ≤ FO < 170MHz	-	0.3	-	0.3	-	0.3	-	0.3	
	170 MHz ≤ FO < 200MHz	-	0.5	-	0.5	-	0.5	-	0.5	
Phase Noise @ 156.25MHz	100Hz	-95		-90		-90		-90		dBc/Hz
	1kHz	-125		-125		-120		-120		
	10kHz	-140		-140		-140		-140		
Aging (@25 1st year)	-	±3	-	±3	-	±3	-	±3	ppm	
Storage Temp. Range	-55	125	-55	125	-55	125	-55	125	°C	

Standard frequencies are frequencies which the crystal has been designed and does not imply a stock position
 .+ Transition times are measured between 10% and 90% of VDD, with an output load of 15pF.

Dimension(mm)

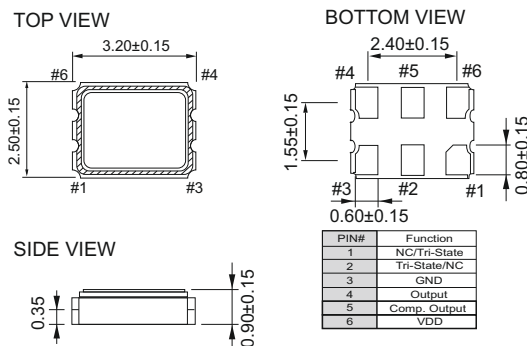

Solder Pad Layout(mm)

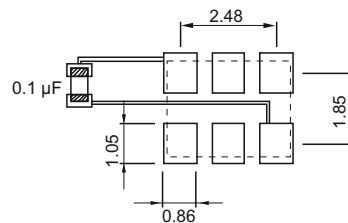

To ensure optimal oscillator performance, place a by-pass capacitor of 0.1 µF as close to the part as possible between Vdd and GND pads.

FREQ. STABILITY vs. TEMP. RANGE

Temp. (°C)	ppm	
	±25	±50
-10 ~ +60	o	o
-20 ~ +70	o	o
-40 ~ +85	Δ	o
-40 ~ +125	X	o

o: Available Δ: Conditional X: Not available
 Inclusive of calibration @ 25 °C, operating temperature range, input voltage variation, load variation, aging (1st year), shock, and vibration

5.0 × 3.2 mm SMD LVPECL /LVDS Crystal Oscillator

Feature

- Typical 5.0 x 3.2 x 1.25mm ceramic SMD package.
- Very low jitter performance: typical 0.3 pS RMS from 12 k - 20 MHz
- Output frequency up to 320 MHz.
- Operating emperature up to 125°C
- Tri-state enable/disable

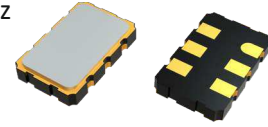

Electrical Specifications

Parameter	LVPECL				LVDS				Unit	
	3.3V		2.5V		3.3V		2.5V			
	Min.	Max.	Min.	Max.	Min.	Max.	Min.	Max.		
Supply Voltage Variation	3.135	3.465	2.375	2.625	3.135	3.465	2.375	2.625	V	
Frequency Range	10	320	10	320	10	320	10	320	MHz	
Standard Frequency	25,106.25,125, 156.25,161.1328,212.5								MHz	
Supply Current	10 MHz ≡ FO<160MHz	-	75	-	75	-	50	-	50	mA
	160 MHz ≡ FO<250MHz	-	100	-	100	-	50	-	50	
	250 MHz ≡ FO<320MHz	-	100	-	100	-	65	-	65	
Output level	Output High	2.275	-	1.475	-	-	1.6	-	1.6	V
	Output Low	-	1.68	-	0.88	0.9	-	0.9	-	
Transition Time : Rise/Fall Time	-	1.0	-	1.0	-	1.0	-	1.0	nSec	
Start Time	-	10	-	10	-	10	-	10	mSec	
Tri-State (Input to Pin 1/2)	Enable	2.31	-	1.75	-	2.31	-	1.75	-	V
	Disable	-	0.99	-	0.75	-	0.99	-	0.75	
RMS Phase Jitter(integrated 12kHz ~ 20MHz)	FO<80MHz	-	1	-	1	-	1	-	1	pSec
	80 MHz ≡ FO<125MHz	-	0.5	-	0.5	-	0.5	-	0.5	
	125 MHz ≡ FO<170MHz	-	0.3	-	0.3	-	0.3	-	0.3	
	170 MHz ≡ FO<200MHz	-	0.5	-	0.5	-	0.5	-	0.5	
	200 MHz ≡ FO	-	0.3	-	0.3	-	0.3	-	0.3	
Phase Noise @156.25MHz	100Hz	-95		-90		-90		-90		dBc/Hz
	1kHz	-125		-125		-120		-120		
	10kHz	-140		-140		-140		-140		
Aging(@25 1st year)	-	±3	-	±3	-	±3	-	±3	ppm	
Storage Temp. Range	-55	125	-55	125	-55	125	-55	125	°C	

Standard frequencies are frequencies which the crystal has been designed and does not imply a stock position
 .+ Transition times are measured between 10% and 90% of VDD, with an output load of 15pF.

Dimension(mm)

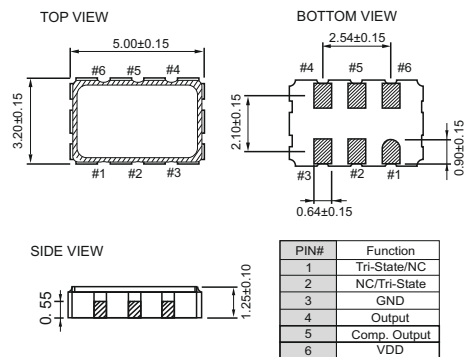

Solder Pad Layout(mm)

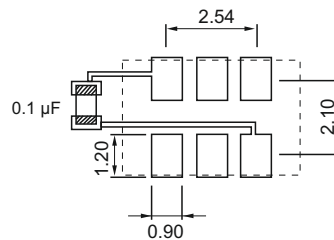

To ensure optimal oscillator performance, place a by-pass capacitor of 0.1 µF as close to the part as possible between Vdd and GND pads.

FREQ. STABILITY vs. TEMP. RANGE

Temp. (°C)	ppm	
	±25	±50
-10 ~ +60	○	○
-20 ~ +70	○	○
-40 ~ +85	△	○
-40 ~ +125	x	○

○: Available △:Conditional X: Not available

Inclusive of calibration @ 25 °C, operating temperature range, input voltage variation, load variation, aging (1st year), shock, and vibration

7.0 × 5.0 mm SMD LVPECL /LVDS Crystal Oscillator

Feature

- Typical 7.0 x 5.0 x 1.45mm ceramic SMD package
- Very low jitter performance: typical 0.3 pS RMS from 12k - 20MHz
- Output frequency up to 320 MHz
- Operating temperature up to 125°C
- Tri-state enable/disable

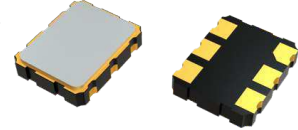

Electrical Specifications

Parameter	LVPECL				LVDS				Unit	
	3.3V		2.5V		3.3V		2.5V			
	Min.	Max.	Min.	Max.	Min.	Max.	Min.	Max.		
Supply Voltage Variation	3.135	3.465	2.375	2.625	3.135	3.465	2.375	2.625	V	
Frequency Range	10	320	10	320	10	320	10	320	MHz	
Standard Frequency	77.76,106.25,125,155.52,156.25,187.5,212.5,312.5								MHz	
Supply Current	10 MHz ≡ FO<160MHz	-	75	-	75	-	50	-	50	mA
	160 MHz ≡ FO<250MHz	-	100	-	100	-	50	-	50	
	250 MHz ≡ FO<320MHz	-	100	-	100	-	65	-	65	
Output level	Output High	2.275	-	1.475	-	1.6	-	1.6	V	
	Output Low	-	1.68	-	0.88	0.9	-	0.9		
Transition Time : Rise/Fall Time	-	1.0	-	1.0	-	1.0	-	1.0	nSec	
Start Time	-	10	-	10	-	10	-	10	mSec	
Tri-State (Input to Pin 1/2)	Enable	2.31	-	1.75	-	2.31	-	1.75	V	
	Disable	-	0.99	-	0.75	-	0.99	-		0.75
RMS Phase Jitter(integrated 12kHz ~ 20MHz)	FO<80MHz	-	1	-	1	-	1	-	1	pSec
	80 MHz ≡ FO<125MHz	-	0.5	-	0.5	-	0.5	-	0.5	
	125 MHz ≡ FO<170MHz	-	0.3	-	0.3	-	0.3	-	0.3	
	170 MHz ≡ FO<200MHz	-	0.5	-	0.5	-	0.5	-	0.5	
Phase Noise @156.25MHz	100Hz	-100		-100		-100		-100		dBc/Hz
	1kHz	-130		-130		-130		-130		
	10kHz	-145		-145		-145		-145		
Aging(@25 1st year)	-	±3	-	±3	-	±3	-	±3	ppm	
Storage Temp. Range	-55	125	-55	125	-55	125	-55	125	°C	

Standard frequencies are frequencies which the crystal has been designed and does not imply a stock position

+ Transition times are measured between 20% and 80% of VDD.

Dimension(mm)

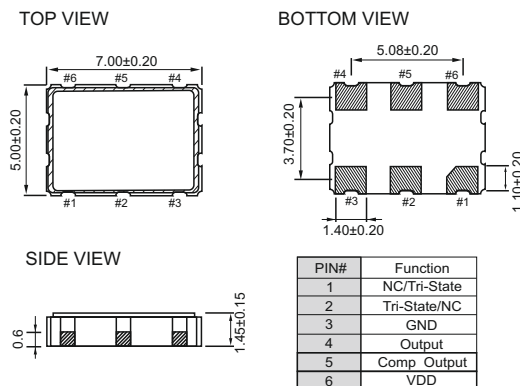

Solder Pad Layout(mm)

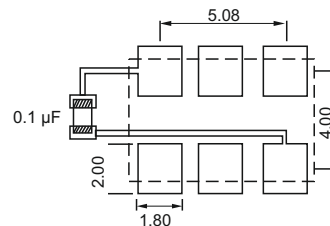

To ensure optimal oscillator performance, place a by-pass capacitor of 0.1 μF as close to the part as possible between Vdd and GND pads.

FREQ. STABILITY vs. TEMP. RANGE

Temp. (°C)	ppm	
	±25	±50
-10 ~ +60	○	○
-20 ~ +70	○	○
-40 ~ +85	△	○
-40 ~ +125	x	○

○: Available △: Conditional X: Not available

Inclusive of calibration @ 25 °C, operating temperature range, input voltage variation, load variation, aging (1st year), shock, and vibration

7.0 × 5.0 mm Ultra Low Phase Jitter LVPECL SMD Crystal Oscillator **Aldinet**

Feature

- Typical 7.0 x 5.0 x 1.45 mm 6 pads SMD package
- Ultra low jitter performance: < 100 fs RMS from 12kHz-20MHz
- Tight symmetry (45 to 55%) available
- Complementary output

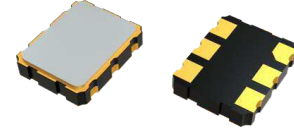

Electrical Specifications

Parameter	LVPECL				Unit
	3.3V		2.5V		
	Min.	Max.	Min.	Max.	
Supply Voltage Variation	3.135	3.465	2.375	2.625	V
Frequency Range	70	170	100	160	MHz
Standard Frequency	100,125,155.52,156.25				MHz
Supply Current	-	75	-	75	mA
Transition Time :Rise/Fall Time	-	1	-	1	nSec
Output Level	Output High	2.275	1.475		V
	Output Low		1.68	1.095	
Start Time	-	10	-	10	mSec
Tri-State (Input to Pin 1 or Pin 2)	Enable	2.31	-	1.75	V
	Disable	-	0.99	-	
RMS Phase Jitter (Integrated 12kHz to 20MHz)	-	0.1	-	0.1	pSec
Phase Noise @156.25MHz	100Hz offset	-100	-100		dBc/Hz
	1kHz offset	-130	-130		dBc/Hz
	10kHz offset	-150	-150		dBc/Hz
Aging (@25°C 1st year)	-	±3	-	±3	ppm
Storage Temp. Range	-55	125	-55	125	°C

Standard frequencies are frequencies which the crystal has been designed and does not imply a stock position

.+ Transition times are measured between 20% and 80% of VDD,

Dimension(mm)

TOP VIEW

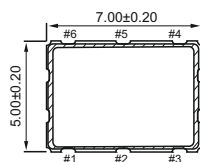

BOTTOM VIEW

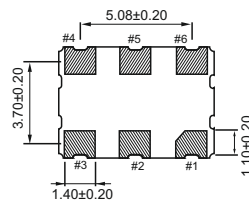

SIDE VIEW

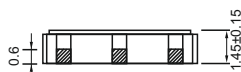

PIN#	Function
1	NC/Tri-State
2	Tri-State/NC
3	GND
4	Output
5	Comp Output
6	VDD

Solder Pad Layout(mm)

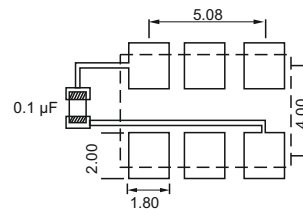

To ensure optimal oscillator performance, place a by-pass capacitor of 0.1 µF as close to the part as possible between Vdd and GND pads.

FREQ. STABILITY vs. TEMP. RANGE

Temp. (°C)	±25 ppm	±50 ppm
-10 ~ +60	Δ	○
-20 ~ +70	Δ	○
-40 ~ +85	X	○

○: Available Δ: Conditional X: Not available

Inclusive of calibration @ 25 °C, operating temperature range, input voltage variation, load variation, aging (1st year), shock, and vibration

7.0 × 5.0 mm SMD HCSL Crystal Oscillator

Feature

- Typical 7.0 x 5.0 x 1.45 mm hermetically sealed ceramic package
- Very low jitter performance: Max. 0.5 pS RMS from 12kHz-20MHz
- Tight symmetry (45 to 55%) available
- Tri-state enable/disable
- High-speed current steering logic (HCSL) output

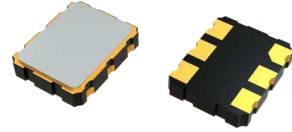

Electrical Specifications

Parameter	HCSL				Unit
	3.3V		2.5V		
	Min.	Max.	Min.	Max.	
Supply Voltage Variation	3.135	3.465	2.375	2.625	V
Frequency Range	25	175	25	175	MHz
Standard Frequency	100				MHz
Supply Current	-	50	-	50	mA
Output level	Output High	0.6	-	0.58	V
	Output Low	-	0.15	0.15	
Transition Time : Rise/Fall Time	-	0.5	-	0.5	nSec
Start Time	-	10	-	10	mSec
Tri-State (Input to Pin 1/2)	Enable	2.31	-	1.75	V
	Disable	-	0.99	-	
RMS Phase Jitter(integrated 12kHz ~ 20MHz)	-	0.5	-	0.5	pSec
Aging(@25 1st year)	-	±3	-	±3	ppm
Storage Temp. Range	-55	125	-55	125	°C

Standard frequencies are frequencies which the crystal has been designed and does not imply a stock position
 .+ Transition times are measured between 20% and 80% of VDD.

Dimension(mm)

TOP VIEW

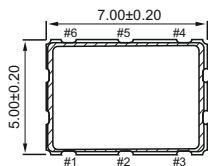

BOTTOM VIEW

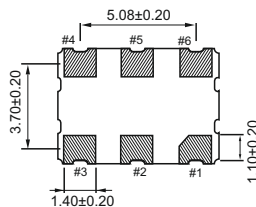

SIDE VIEW

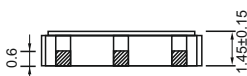

PIN#	Function
1	NC/Tri-State
2	Tri-State/NC
3	GND
4	Output
5	Comp Output
6	VDD

Solder Pad Layout(mm)

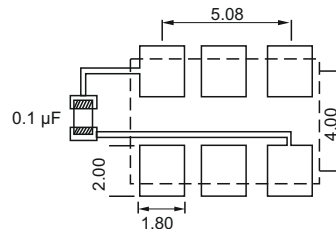

To ensure optimal oscillator performance, place a by-pass capacitor of 0.1 µF as close to the part as possible between Vdd and GND pads.

FREQ. STABILITY vs. TEMP. RANGE

Temp. (°C)	ppm	
	±25	±50
-10 ~ +60	o	o
-20 ~ +70	o	o
-40 ~ +85	Δ	o
-40 ~ +125	x	o

o: Available Δ: Conditional X: Not available
 Inclusive of calibration @ 25 °C, operating temperature range, input voltage variation, load variation, aging (1st year), shock, and vibration

3.2 x 2.5 mm SMD CMOS Output Voltage Controlled Crystal Oscillator

Feature

- Low power supply voltage: 3.3, 2.5 supply options.
- Frequency support from 10MHz to 250MHz.
- Low phase jitter typical: 0.8ps RMS from 12kHz TO 20MHz.
- Wide frequency control range. Tri-state enable/disable function
- Temperature range: -40 to 85°C operation
- Pb-free/ RoHS compliant

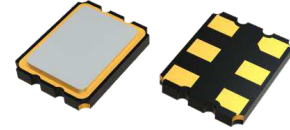

Electrical Specifications

Parameter	CMOS				Unit
	3.3V		2.5V		
	Min.	Max.	Min.	Max.	
Supply Voltage Variation(VDD)	VDD-10%	VDD+10%	VDD-5%	VDD+5%	V
Frequency Range	10	250	10	250	MHz
Supply Current	-	50	-	45	mA
Output Level	Output High	-	2.25	-	V
	Output Low	0.33	-	0.25	
Transition Time (10% ~ 90%) Rise/Fall Time +	-	1.0	-	1.0	nSec
Duty Cycle	45	55	45	55	%
Start Time	-	10	-	10	mSec
Tri-State (input to Pin 2)					
Enable	70%VDD	-	70%VDD	-	V
Disable	-	30%VDD	-	30%VDD	
Stand by Current	-	18	-	18	mA
Output Loading (10MHz to 200MHz)	-	15	-	15	pf
Output Loading (200MHz to 250MHz)	-	5	-	5	pf
Phase Noise	Typ.	Max.	Typ.	Max.	
At VDD=3.3V, f _{out} =250MHz	1kHz offset	-107	-	-107	dBc/Hz
	10kHz offset	-111	-	-111	
	100kHz offset	-114	-	-114	
	1MHz offset	-125	-	-125	
	20MHz offset	-147	-	-147	
RMS Phase Jitter (12 kHz~20 MHz)	0.8	1.5	0.8	1.5	pSec
Control Voltage Center	1.65		1.25		V
Control Voltage Range	0.3	3	0.25	2.25	V
Frequency Pulling Range	± 50	± 150	± 50	± 150	ppm

Dimension(mm)

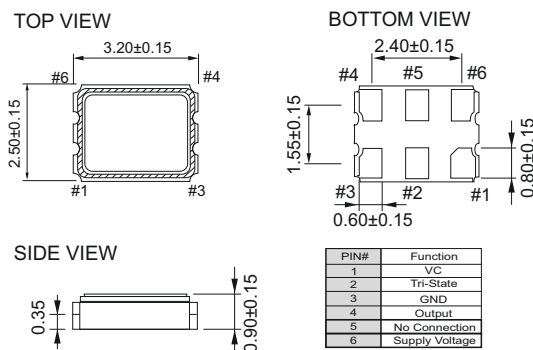

Solder Pad Layout(mm)

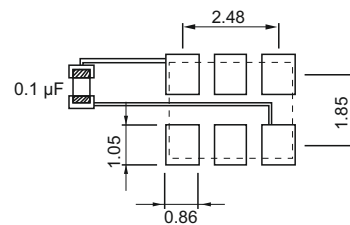

To ensure optimal oscillator performance, place a by-pass capacitor of 0.1 μF as close to the part as possible between Vdd and GND pads.

FREQ. STABILITY vs. TEMP. RANGE

Temp. (°C)	ppm ±25	ppm ±50
-10 ~ +60	O	O
-20 ~ +70	O	O
-40 ~ +85	△	O

o: Available △: Conditional X: Not available

Inclusive of calibration @ 25 °C, operating temperature range, input voltage variation, load variation, aging (1 st year), shock, and vibration

5.0 x 3.2 mm SMD Voltage Controlled Crystal Oscillator

Feature

- Typical 5.0 x 3.2 x 1.25 mm 6 pads ceramic SMD package
- Tight symmetry (45 to 55%) available
- Output frequency up to 250 MHz
- Tri-state enable/disable
- Pb-free/ RoHS compliant



Electrical Specifications

Parameter	2.5V / 3.3V		Unit
	Min.	Max.	
Supply Voltage Variation(VDD)	VDD-5%	VDD+5%	V
Frequency Range	10	250	MHz
Absolute Pulling Range (APR)	±50	-	ppm
Control Voltage Range	0.3	3.0	V
Supply Current	10 MHz ≅ Fo < 160 MHz	-	mA
	160 MHz ≅ Fo ≅ 250 MHz	40	
Output Level (CMOS)	Output High (Logic"1")	2.97	V
	Output Low (Logic"0")	0.33	
Transition Time (10% ~ 90%) Rise/Fall Time +	-	2	nSec
Duty Cycle	45	55	%
Start Time	-	2	mSec
Tri-State (input to Pin 2)	Enable	2.31	V
	Disable	-	
Period Jitter (Pk-Pk)	-	150	pSec
RMS Phase Jitter (Integrated 12kHz~20MHz)	-	1	pSec
Linearity	-	10	%
Modulation Bandwidth (BW)	10	-	kHz
Input Impedance	1000	-	kΩ
Phase Noise@155.52MHz	100 Hz	-75	dBc/Hz
	1 kHz	-105	
	10kHz	-125	
Aging (@ 25°C 1st year)	-	±3	ppm
Storage Temp. Range	-55	125	°C

Standard frequencies are frequencies which the crystal has been designed and does not imply a stock position.
 + Transition times are measured between 10% and 90% of V DD , with an output load of 15pF.

Dimension(mm)

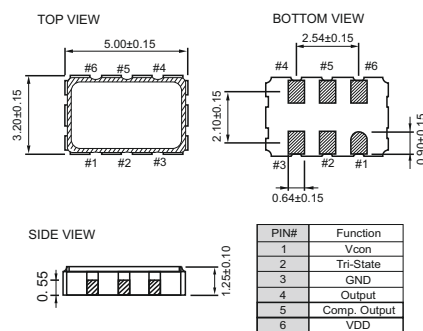

Solder Pad Layout(mm)

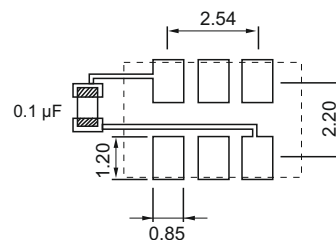

To ensure optimal oscillator performance, place a by-pass capacitor of 0.1 μF as close to the part as possible between Vdd and GND pads.

FREQ. STABILITY vs. TEMP. RANGE

Temp. (°C)	ppm	
	±25	±50
-10 ~ +60	O	O
-20 ~ +70	O	O
-40 ~ +85	Δ	O

O: Available Δ: Conditional X: Not available
 Inclusive of calibration @ 25 °C, operating temperature range, input voltage variation, load variation, aging (1 st year), shock, and vibration

7.0 x 5.0 mm SMD Voltage Controlled Crystal Oscillator

Feature

- Typical 7.0 x 5.0 x 1.75 mm 6 pads ceramic SMD package.
- Tight symmetry (45 to 55%) available.
- Output frequency up to 250 MHz.
- Tri-state enable/disable
- Pb-free/ RoHS compliant

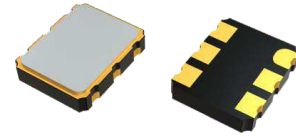

Electrical Specifications

Parameter	2.5V / 3.3V		Unit
	Min.	Max.	
Supply Voltage Variation(VDD)	VDD-5%	VDD+5%	V
Frequency Range	10	250	MHz
Absolute Pulling Range (APR)	±50	-	ppm
Control Voltage Range	0.3	3.0	V
Supply Current	10 MHz ≤ Fo < 160 MHz	-	mA
	160 MHz ≤ Fo ≤ 250 MHz	-	
Output Level (CMOS)	Output High (Logic"1")	2.97	V
	Output Low (Logic"0")	0.33	
Transition Time (10% ~ 90%) Rise/Fall Time +	-	2	nSec
Start Time	-	2	mSec
Tri-State (input to Pin 2)	Enable	2.31	V
	Disable	-	
Period Jitter (Pk-Pk)	-	150	pSec
RMS Phase Jitter (Integrated 12kHz~20MHz) (At Integer Mode)	-	1	pSec
Linearity	-	10	%
Modulation Bandwidth (BW)	10	-	kHz
Input Impedance	1000	-	kΩ
Phase Noise@155.52MHz	100 Hz	-75	dBc/Hz
	1 kHz	-105	
	10kHz	-125	
Aging (@ 25 °C 1st year)	-	±3	ppm
Storage Temp. Range	-55	125	°C

Standard frequencies are frequencies which the crystal has been designed and does not imply a stock position.
 + Transition times are measured between 10% and 90% of V DD , with an output load of 15pF.

Dimension(mm)

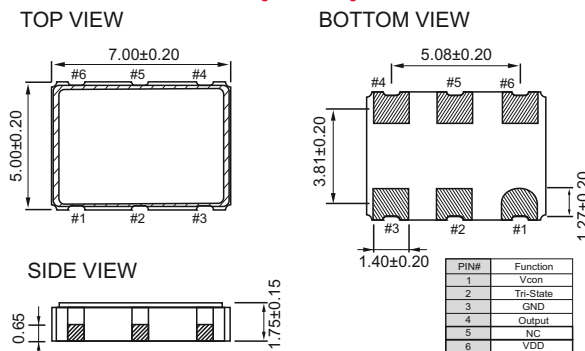

Solder Pad Layout(mm)

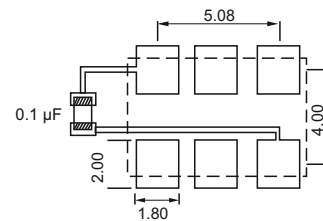

To ensure optimal oscillator performance, place a by-pass capacitor of 0.1 μF as close to the part as possible between Vdd and GND pads.

FREQ. STABILITY vs. TEMP. RANGE

Temp. (°C)	ppm ±25	ppm ±50
-10 ~ +60	O	O
-20 ~ +70	O	O
-40 ~ +85	Δ	O

o: Available Δ: Conditional X: Not available

Inclusive of calibration @ 25 °C, operating temperature range, input voltage variation, load variation, aging (1 st year), shock, and vibration

High Frequency up to 1.5GHz 3.2 x 2.5 mm SMD Differential Output Voltage Controlled Crystal Oscillator

Feature

- Low power supply voltage: 3.3V, 2.5V supply options
- Differential output :VPECL, LVDS
- Frequency support from 10MHz to 1.5GHz
- Low phase jitter typical: 0.8 ps RMS from 12kHz to 20MHz
- Wide frequency control range
- Pb-free/RoHS compliant

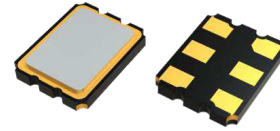

Electrical Specifications

Parameter	LVPECL				LVDS				Unit
	3.3V		2.5V		3.3V		2.5V		
	Min.	Max.	Min.	Max.	Min.	Max.	Min.	Max.	
Supply Voltage Variation	VDD-10%	VDD+10%	VDD-5%	VDD+5%	VDD-10%	VDD+10%	VDD-5%	VDD+5%	V
Frequency Range	10	1500	10	1500	10	1500	10	1500	MHz
Supply Current	-	50	-	45	-	45	-	35	mA
Duty Cycle	45	55	45	55	45	55	45	55	%
Transition Time : Rise/Fall Time	-	1.0	-	1.0	-	1.0	-	1.0	nSec
Output Level	Out High(Logic"1")	2.27	2.7	1.47	1.9	1.6	-	1.6	V
	Out Low(Logic"0")	1.45	1.7	0.65	0.9	0.9	0.9	-	
Start Time	-	10	-	10	-	10	-	10	mSec
Tri-State (Input to Pin 2)	Enable(High Voltage or floating)	0.7V _{DD}	-	0.7V _{DD}	-	0.7V _{DD}	-	0.7V _{DD}	V
	Disable(Low Voltage or GND)	-	0.3 V _{DD}	-	0.3 V _{DD}	-	0.3 V _{DD}	-	
Standby by Current	-	18	-	18	-	18	-	18	mA
Output Loading	50Ω into VDD-2V				100Ω				
RMS Phase Jitter (integrated 12kHz to 20MHz)	0.8	1.5	0.8	1.5	0.8	1.5	0.8	1.5	pSec
Control Voltage Function on Pin1									
Control Voltage Center	1.65		1.25		1.65		1.25		V
Control Voltage Range	0.3	3	0.3	3	0.3	3	0.3	3	V
Absolute Pulling Range (APR)	±50	±150	±50	±150	±50	±150	±50	±150	ppm
Linearity	5	10	5	10	5	10	5	10	%
Modulation Bandwidth	10	-	10	-	10	-	10	-	kHz
VC Input Impedance	1	-	1	-	1	-	1	-	MΩ

Dimension(mm)

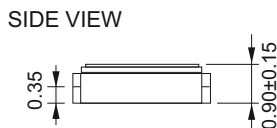
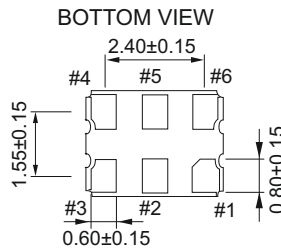
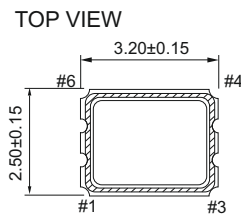

PIN#	Function
1	VC
2	Tri-State
3	GND
4	Output
5	Comp. Output
6	Supply Voltage

Solder Pad Layout(mm)

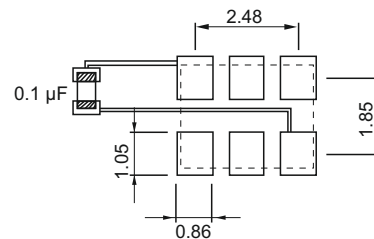

To ensure optimal oscillator performance, place a by-pass capacitor of 0.1 μF as close to the part as possible between Vdd and GND pads.

FREQ. STABILITY vs. TEMP. RANGE

Temp. (°C)	ppm ±25	ppm ±50
-10 ~ +60	0	0
-20 ~ +70	0	0
-40 ~ +85	Δ	0

o: Available Δ: Conditional X: Not available

Inclusive of calibration @ 25 °C, operating temperature range, input voltage variation, load variation, aging (1 st year), shock, and vibration

5.0 x 3.2 mm SMD Differential Output Voltage Controlled Crystal Oscillator

Feature

- Differential output: VPECL, LVDS
- Frequency support from 10MHz to 1.5GHz
- Low phase jitter typical: <1ps RMS from 12kHz to 20MHz
- Wide frequency control range
- Pb-free/RoHS compliant

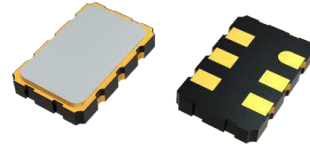

Electrical Specifications

Parameter	LVPECL				LVDS				Unit	
	3.3V		2.5V		3.3V		2.5V			
	Min.	Max.	Min.	Max.	Min.	Max.	Min.	Max.		
Supply Voltage Variation	VDD-5%	VDD+5%	VDD-5%	VDD+5%	VDD-5%	VDD+5%	VDD-5%	VDD+5%	V	
Frequency Range	10	1500	10	1500	10	1500	10	1500	MHz	
Supply Current	10MHz ≅ FO<160MHz	-	75	-	75	-	50	-	50	mA
	160MHz ≅ FO<1500MHz	-	100	-	100	-	75	-	75	
Duty Cycle	45	55	45	55	45	55	45	55	%	
Transition Time : Rise/Fall Time	-	1.0	-	1.0	-	1.0	-	1.0	nSec	
Output Level	Out High (Logic "1")	2.27		2.27		1.6		1.6	V	
	Out Low (Logic "0")		1.7		1.7	0.9		0.9		
Start Time	-	10	-	10	-	10	-	10	mSec	
Tri-State (Input to Pin 2)	Enable (High Voltage or floating)	0.7V _{DD}	-	0.7V _{DD}	-	0.7V _{DD}	-	0.7V _{DD}	-	V
	Disable (Low Voltage or GND)	-	0.3 V _{DD}	-	0.3 V _{DD}	-	0.3 V _{DD}	-	0.3 V _{DD}	
RMS Phase Jitter (integrated 12kHz to 20MHz)		1		1		1		1	pSec	
Control Voltage Function on Pin1										
Control Voltage Center	1.65		1.25		1.65		1.25		V	
Control Voltage Range	0.3	3	0.3	3	0.3	3	0.3	3	V	
Absolute Pulling Range (APR)	±50		±50		±50		±50		ppm	
Linearity	10		10		10		10		%	
Modulation Bandwidth	10	-	10	-	10	-	10	-	kHz	
VC Input Impedance	1	-	1	-	1	-	1	-	MΩ	
Aging (@25 1st year)	-	±3	-	±3	-	±3	-	±3	ppm	
Storage Temp. Range	-55	125	-55	125	-55	125	-55	125	°C	

Standard frequencies are frequencies which the crystal has been designed and does not imply a stock position
 + Transition times are measured between 20% and 80% of V_{DD}.

Dimension(mm)

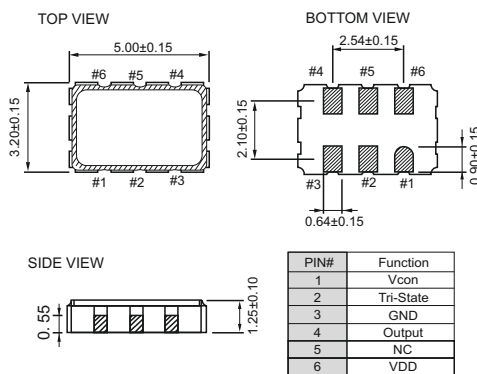

Solder Pad Layout(mm)

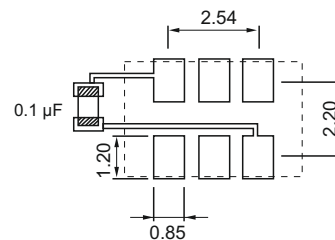

To ensure optimal oscillator performance, place a by-pass capacitor of 0.1 μF as close to the part as possible between V_{DD} and GND pads.

FREQ. STABILITY vs. TEMP. RANGE

Temp. (°C)	ppm	
	±25	±50
-10 ~ +60	O	O
-20 ~ +70	Δ	O
-40 ~ +85	Δ	O

O: Available Δ: Conditional X: Not available

Inclusive of calibration @ 25 °C, operating temperature range, input voltage variation, load variation, aging (1 st year), shock, and vibration

7.0 x 5.0 mm SMD Differential Output Voltage Controlled Crystal Oscillator

Feature

- Differential output :VPECL, LVDS
- Frequency support from 10MHz to 1.5GHz
- Low phase jitter typical:<1ps RMS from 12kHz to 20MHz
- Wide frequency control range
- Pb-free/RoHS compliant

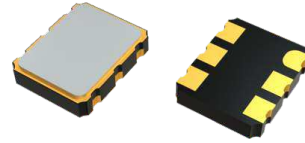

Electrical Specifications

Parameter	LVPECL				LVDS				Unit	
	3.3V		2.5V		3.3V		2.5V			
	Min.	Max.	Min.	Max.	Min.	Max.	Min.	Max.		
Supply Voltage Variation	VDD-10%	VDD+10%	VDD-5%	VDD+5%	VDD-10%	VDD+10%	VDD-5%	VDD+5%	V	
Frequency Range	10	1500	10	1500	10	1500	10	1500	MHz	
Supply Current	10MHz ≦ F<160MHz	-	75	-	75	-	50	-	50	mA
	160MHz ≦ FO<1500MHz	-	100	-	100	-	75	-	75	
Duty Cycle	45	55	45	55	45	55	45	55	%	
Transition Time : Rise/Fall Time	-	1.0	-	1.0	-	1.0	-	1.0	nSec	
Output Level	Out High(Logic"1")	2.27		2.27		1.6		1.6	V	
	Out Low(Logic"0")		1.7		1.7	0.9		0.9		
Start Time	-	10	-	10	-	10	-	10	mSec	
Tri-State (Input to Pin 2)	Enable(High Voltage or floating)	0.7V _{DD}	-	0.7V _{DD}	-	0.7V _{DD}	-	0.7V _{DD}	V	
	Disable(Low Voltage or GND)	-	0.3 V _{DD}	-	0.3 V _{DD}	-	0.3 V _{DD}	-		0.3 V _{DD}
RMS Phase Jitter (integrated 12kHz to 20MHz)		1		1		1		1	pSec	
Control Voltage Function on Pin1										
Control Voltage Center	1.65		1.25		1.65		1.25		V	
Control Voltage Range	0.3	3	0.3	3	0.3	3	0.3	3	V	
Absolute Pulling Range (APR)	±50		±50		±50		±50		ppm	
Linearity	10		10		10		10		%	
Modulation Bandwidth	10	-	10	-	10	-	10	-	kHz	
VC Input Impedance	1	-	1	-	1	-	1	-	MΩ	
Aging (@25 1st year)	-	±3	-	±3	-	±3	-	±3	ppm	
Storage Temp. Range	-55	125	-55	125	-55	125	-55	125	°C	

Dimension(mm)

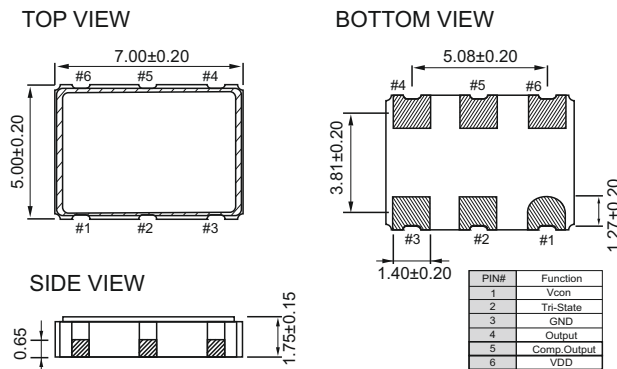

Solder Pad Layout(mm)

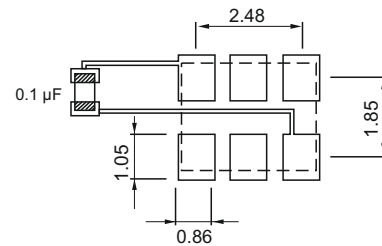

To ensure optimal oscillator performance, place a by-pass capacitor of 0.1 μF as close to the part as possible between V_{DD} and GND pads.

FREQ. STABILITY vs. TEMP. RANGE

Temp. (°C)	±25 ppm	±50 ppm
-10 ~ +60	○	○
-20 ~ +70	△	○
-40 ~ +85	△	○

○: Available △:Conditional X: Not available

Inclusive of calibration @ 25 °C, operating temperature range, input voltage variation, load variation, aging (1 st year), shock, and vibration

5.0 x 3.2mm SMD LVPECL/LVDS Voltage Controlled Crystal Oscillator

Feature

- Typical 5.0 x 3.2 x 1.25 mm 6 pads ceramic SMD package.
- Tight symmetry (45 to 55%) available.
- Tri-state enable/disable

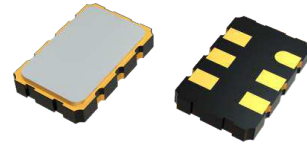

Electrical Specifications

Parameter	LVPECL 3.3V		LVDS 3.3V		Unit
	Min.	Max.	Min.	Max.	
Supply Voltage Variation(VDD)	VDD-5%	VDD+5%	VDD-5%	VDD+5%	V
Frequency Range	30	250	30	250	MHz
Standard Frequency	122.88,153.6,155.52,156.25				MHz
Absolute Pulling Range (APR)	±50		±50	-	ppm
Control Voltage Range	0.3	3.0	0.3	3.0	V
Supply Current 30MHz Fo 250 MHz		100		75	mA
Output Level	Output High (logic"1")	2.275	-	1.6	V
	Output Low (logic"0")		1.68	0.9	
Transition Time: Rise/Fall Time +		1.0		1.0	nSec
Start Time		3		3	mSec
Tri-State (input to Pin 2)	Enable (High voltage or floating)	2.31		2.31	V
	Disable (Low voltage or GND)		0.99	0.99	
Linearity		10		10	%
Modulation Bandwidth (BW)	20		20		kHz
Input Impedance	1		1		MΩ
RMS Phase Jitter	F0 < 100 MHz		1.0	1.0	pSec
	100 MHz ≅ F0 < 125 MHz		0.7	0.7	
	125 MHz ≅ F0 < 150 MHz		0.5	0.5	
	150 MHz ≅ F0 < 250 MHz		0.3	0.3	
Phase Noise @122.88MHz	100 Hz	-105		-105	dBc/HZ
	1kHz	-128		-128	
	10kHz	-145		-145	
Aging (@ 25°C 1st year)		±3		±3	ppm
Storage Temp. Range	-55	125	-55	125	°C

Standard frequencies are frequencies which the crystal has been designed and does not imply a stock position
 + Transition times are measured between 20% and 80% of VDD.

Dimension(mm)

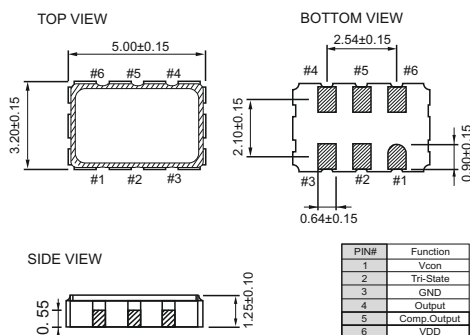

Solder Pad Layout(mm)

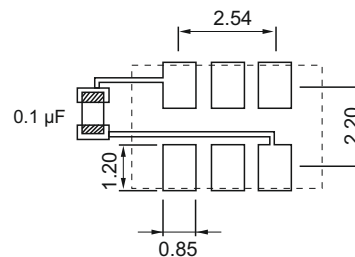

To ensure optimal oscillator performance, place a by-pass capacitor of 0.1 μF as close to the part as possible between Vdd and GND pads.

FREQ. STABILITY vs. TEMP. RANGE

Temp. (°C)	ppm ±25	ppm ±50
-10 ~ +60	O	O
-20 ~ +70	O	O
-40 ~ +85	X	O

O: Available Δ: Conditional X: Not available

Inclusive of calibration @ 25 °C, operating temperature range, input voltage variation, load variation, aging (1 st year), shock, and vibration

7.0 x 5.0 mm SMD LVPECL/LVDS Voltage Controlled Crystal Oscillator

Feature

- Typical 7.0 x 5.0 x 1.75 mm 6 pads ceramic SMD package.
- Very low jitter performance: typical 0.3 pS RMS from 12kHz-20MHz.
- Wide frequency control range.
- Complementary Output.
- Tri-state enable/disable.

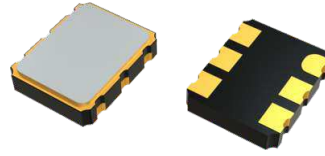

Electrical Specifications

Parameter	LVPECL				LVDS				Unit	
	3.3 V		2.5 V		3.3 V		2.5 V			
	Min.	Max.	Min.	Max.	Min.	Max.	Min.	Max.		
Supply Voltage Variation(VDD)	VDD-5%	VDD+5%	VDD-5%	VDD+5%	VDD-5%	VDD+5%	VDD-5%	VDD+5%	V	
Frequency Range	1.5	200	65	200	1.5	200	65	200	MHz	
Standard Frequency	77.76,106.25,122.88,125,155.52,156.25,200								MHz	
Absolute Pulling Range (APR)	±50	-	±50	-	±50	-	±50	-	ppm	
Control Voltage Range	0.3	3.0	0	2.5	0.3	3.0	0	2.5	V	
Supply Current	1.5 MHz F ₀ < 65 MHz	-	75	-	75	-	45	-	45	mA
	65 MHz F ₀ < 200 MHz	-	100	-	100	-	80	-	80	
Output Level	Output High	2.275	-	1.475	-	1.6	-	1.6	V	
	Output Low	-	1.68	-	1.095	0.9	-	0.9		
Transition Time: Rise/Fall Time +	-	1.0	-	1.0	-	1.0	-	1.0	nSec	
Start Time	-	3	-	3	-	3	-	3	mSec	
Tri-State (input to PIN2)	Enable (Highvoltage or floating)	2.31	-	1.75	-	2.31	-	1.75	V	
	Disable (Lowvoltage or GND)	-	0.99	-	0.75	-	0.99	-		0.75
Linearity	-	10	-	10	-	10	-	10	%	
Modulation Bandwidth (BW)	15	-	15	-	15	-	15	-	kHz	
Input Impedance	1	-	1	-	1	-	1	-	Mhz	
RMS Phase Jitter (Integrated 12kHz~20MHz)	F ₀ < 100 MHz	-	1.0	-	1.0	-	1.0	-	1.0	pSec
	100 MHz F ₀ < 125 MHz	-	0.7	-	0.7	-	0.7	-	0.7	
	125 MHz F ₀ < 150 MHz	-	0.5	-	0.5	-	0.5	-	0.5	
	150 MHz F ₀	-	0.3	-	0.3	-	0.3	-	0.3	
Phase Noise @153.6 MHz	100 Hz	-	-85	-	-85	-	-85	-	-85	dBc/Hz
	1kHz	-	-115	-	-115	-	-115	-	-115	
	10kHz	-	-130	-	-130	-	-130	-	-130	
Aging (@ 25 C 1st year)	-	±3	-	±3	-	±3	-	±3	ppm	
Storage Temp. Range	-55	125	-55	125	-55	125	-55	125	°C	

Standard frequencies are frequencies which the crystal has been designed and does not imply a stock position
 + Transition times are measured between 20% and 80% of VDD.

Dimension(mm)

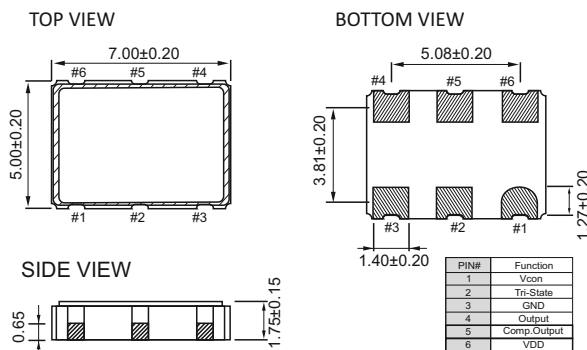

Solder Pad Layout(mm)

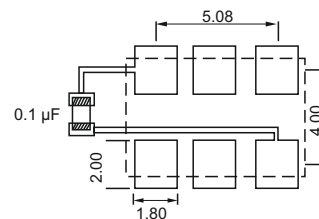

To ensure optimal oscillator performance, place a by-pass capacitor of 0.1 µF as close to the part as possible between Vdd and GND pads.

FREQ. STABILITY vs. TEMP. RANGE

ppm / Temp. (°C)	±25	±50
-10 ~ +60	△	○
-20 ~ +70	△	○
-40 ~ +85	X	○

○: Available △:Conditional X: Not available

Inclusive of calibration @ 25 °C, operating temperature range, input voltage variation, load variation, aging (1 st year), shock, and vibration

5.0 x 3.2mm SMD Voltage Controlled Crystal Oscillator

Feature

- Typical 5.0 x 3.2 x 1.25 mm 6 pads ceramic SMD package.
- Tight symmetry (45 to 55%) available.
- Operating temperature up to 105°C.
- Tri-state enable/disable.

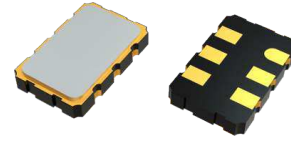

Electrical Specifications

Parameter	3.3V		Unit	
	Min.	Max.		
Supply Voltage Variation(VDD)	VDD-5%	VDD+5%	V	
Frequency Range	1.5	170	MHz	
Standard Frequency	19.44, 38.4		MHz	
Absolute Pulling Range (APR)	±50		ppm	
Control Voltage Range	0.3	3.0	V	
Supply Current	1.5MHz ≅ F0 < 20 MHz	10	mA	
	20MHz ≅ F0 < 50 MH	20		
	50MHz ≅ F0 ≅ 170 MHz	30		
Output Level	Output High	2.97	V	
	Output Low	-		0.33
Transition Time: Rise/Fall Time +	1.5 MHz ≅ F0 < 20 MHz	-	nSec	
	20 MHz ≅ F0 < 50 MHz	-		5
	50 MHz ≅ F0 ≅ 170 MHz	-		4
Start Time	-	2	mSec	
Tri-State (input to Pin 2)	Enable (High voltage or floating)	2.31	V	
	Disable (Low voltage or GND)	-		0.99
Linearity		10	%	
Modulation Bandwidth (BW)	15	-	kHz	
Input Impedance	10	-	MΩ	
Period Jitter (Pk-Pk)	-	40	pSec	
RMS Phase Jitter (Integrated 12 kHz ~ 20 MHz)	-	1	pSec	
Phase Noise @38.4MHz	100 Hz	-100	dBc/HZ	
	1kHz	-133		
	10kHz	-140		
Aging (@ 25°C 1st year)		±3	Ppm	
Storage Temp. Range	-55	125	°C	

Standard frequencies are frequencies which the crystal has been designed and does not imply a stock position
 + Transition times are measured between 20% and 80% of VDD.

Dimension(mm)

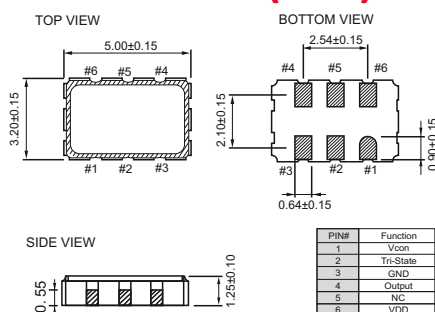

Solder Pad Layout(mm)

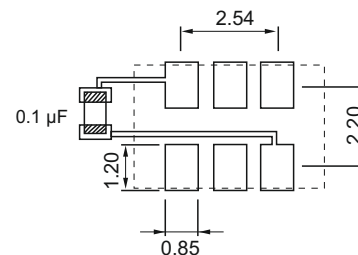

To ensure optimal oscillator performance, place a by-pass capacitor of 0.1 µF as close to the part as possible between Vdd and GND pads.

FREQ. STABILITY vs. TEMP. RANGE

Temp. (°C)	ppm	±25	±50
-10 ~ +60		O	O
-20 ~ +70		O	O
-40 ~ +85		X	O
-40 ~ +105		X	O

o: Available Δ: Conditional X: Not available

Inclusive of calibration @ 25 °C, operating temperature range, input voltage variation, load variation, aging (1 st year), shock, and vibration

7.0 x 5.0 mm SMD Voltage Controlled Crystal Oscillator

Feature

- Typical 7.0 x 5.0 x 1.75 mm 6 pads ceramic SMD package.
- Tight symmetry (45 to 55%) available.
- Operating emperature up to 105°C.
- Tri-state enable/disable

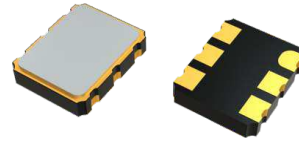

Electrical Specifications

Parameter	3.3V		Unit	
	Min.	Max.		
Supply Voltage Variation(VDD)	VDD-5%	VDD+5%	V	
Frequency Range	1.5	170	MHz	
Standard Frequency	10,20,25,27,32.768,35.328,38.88,61.44,122.88, 153.6		MHz	
Absolute Pulling Range (APR)	±50		ppm	
Control Voltage Range	0.3	3.0	V	
Supply Current	1.5MHz ≡ F0 < 20 MHz	10	mA	
	20MHz ≡ F0 < 50 MH	20		
	50MHz ≡ F0 ≡ 80 MHz	30		
	80MHz ≡ F0 ≡ 160 MHz	40		
	160MHz ≡ F0 ≡ 170 MHz	50		
Output Level	Output High	2.97	V	
	Output Low	-		0.33
Transition Time: Rise/Fall Time +	1.5 MHz ≡ F0 < 20 MHz	-	5	nSec
	20 MHz ≡ F0 < 50 MHz	-	4	
	50 MHz ≡ F0 ≡ 80 MHz	-	3	
	80 MHz ≡ F0 ≡ 170 MHz	-	2	
Start Time	-	5	mSec	
Tri-State (input to Pin 2)	Enable (High voltage or floating)	2.31	-	V
	Disable (Low voltage or GND)	-	0.99	
Linearity		10	%	
Modulation Bandwidth (BW)	15	-	kHz	
Input Impedance	10	-	MΩ	
Period Jitter (Pk-Pk)	-	40	pSec	
RMS Phase Jitter (Integrated 12kHz ~ 20 MHz)	-	1	pSec	
Phase Noise @38.4MHz	100 Hz	-115	dBc/Hz	
	1kHz	-135		
	10kHz	-150		
Aging (@ 25°C 1st year)		±3	Ppm	
Storage Temp. Range	-55	125	°C	

Standard frequencies are frequencies which the crystal has been designed and does not imply a stock position
 + Transition times are measured between 10% and 90% of VDD, with an output load of 15pF.

Dimension(mm)

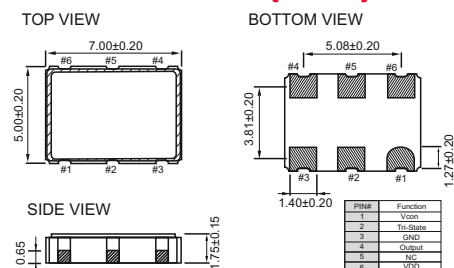

Solder Pad Layout(mm)

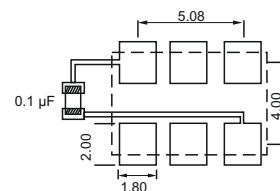

To ensure optimal oscillator performance, place a by-pass capacitor of 0.1 µF as close to the part as possible between Vdd and GND pads.

FREQ. STABILITY vs. TEMP. RANGE

Temp. (°C) \ ppm	±25	±50
-10 ~ +60	O	O
-20 ~ +70	O	O
-40 ~ +85	X	O
-40 ~ +105	X	O

o: Available Δ: Conditional X: Not available
 Inclusive of calibration @ 25 °C, operating temperature range, input voltage variation, load variation, aging (1 st year), shock, and vibration

14.2 x9.3 mm SMD LVPECL/LVDS Voltage Controlled Crystal Oscillator

Aldinet

Feature

- Typical 14.2 x 9.3 x 5.4 mm 6 pads ceramic SMD package
- Tight symmetry (45 to 55%) available
- Wide frequency control range
- Complementary Output
- Low phase jitter (Max:0.5 pSec)

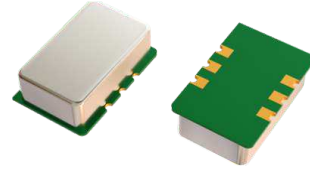

Electrical Specifications

Parameter	LVPECL				LVDS				Unit	
	3.3V		2.5V		3.3V		2.5V			
	Min.	Max.	Min.	Max.	Min.	Max.	Min.	Max.		
Supply Voltage Variation(VDD)	VDD-5%	VDD+5%	VDD-5%	VDD+5%	VDD-5%	VDD+5%	VDD-5%	VDD+5%	V	
Frequency Range	30	250	30	250	30	250	30	250	MHz	
Standard Frequency	77.76,106.25,122.88,125,155.52,156.25,200								MHz	
Absolute Pulling Range (APR)	±50	-	±50	-	±50	-	±50	-	ppm	
Control Voltage Range	0.3	3.0	0	2.5	0.3	3.0	0	2.5	V	
Supply Current	1.5 MHz ≡ F0 < 65 MHz	-	75	-	75	-	45	-	45	mA
	65 MHz ≡ F0 < 250 MHz	-	100	-	100	-	80	-	80	
Output Level	Output High	2.275	-	1.475	-	-	1.6	-	1.6	V
	Output Low	-	1.68	-	1.095	0.9	-	0.9	-	
Transition Time: Rise/Fall Time +	-	1.0	-	1.0	-	1.0	-	1.0	nSec	
Start Time	3								mSec	
Tri-State (input to Pin 2)	Enable (High voltage or floating)	-	0.99	-	0.75	-	0.99	-	0.75	V
	Disable (Low voltage or GND)	2.31	-	1.75	-	2.31	-	1.75	-	
Linearity	-	10	-	10	-	10	-	10	%	
Modulation Bandwidth (BW)	15	-	15	-	15	-	15	-	kHz	
Input Impedance	10	-	10	-	10	-	10	-	MΩ	
RMS Phase Jitter (Integrated 12kHz~20MHz)	F0 < 100 MHz	-	1.0	-	1.0	-	1.0	-	1.0	pSec
	100 MHz ≡ F0 < 125 MHz	-	0.7	-	0.7	-	0.7	-	0.7	
	125 MHz ≡ F0 < 150 MHz	-	0.5	-	0.5	-	0.5	-	0.5	
	150 MHz ≡ F0	-	0.3	-	0.3	-	0.3	-	0.3	
Phase Noise @155.52MHz	100 Hz	-85		-85		-85		-85		dBc/Hz
	1kHz	-115		-115		-115		-115		
	10kHz	-130		-130		-130		-130		
Aging (@ 25°C 1st year)	-	±3	-	±3	-	±3	-	±3	Ppm	
Storage Temp. Range	-55	125	-55	125	-55	125	-55	125	°C	

Standard frequencies are frequencies which the crystal has been designed and does not imply a stock position
 + Transition times are measured between 20% and 80% of VDD.

Dimension(mm)

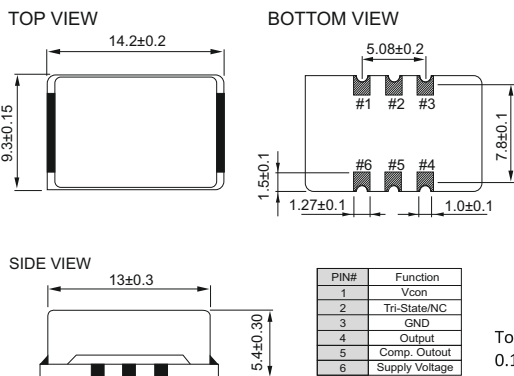

Solder Pad Layout(mm)

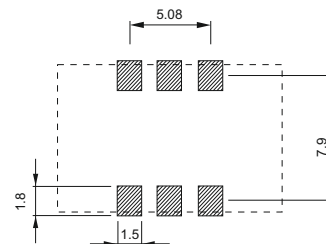

To ensure optimal oscillator performance, place a by-pass capacitor of 0.1 μF as close to the part as possible between VDD and GND pads.

FREQ. STABILITY vs. TEMP. RANGE

ppm / Temp. (°C)	±25	±50
-10 ~ +60	△	O
-20 ~ +70	△	O
-40 ~ +85	X	O

o: Available △:Conditional X: Not available
 Inclusive of calibration @ 25 °C, operating temperature range, input voltage variation, load variation, aging (1 st year), shock, and vibration

Voltage Controlled Crystal Oscillator Full/Half Size(VCXO)

Feature

- Size 20.3x12.6mm and 12.6x12.6mm
- Hybrid IC Circuit Construction
- CMOS compatible output
- All metal, hermetically sealed welded package



Electrical Specifications

Item	Specifications	
Frequency Range	1MHz~80MHz	
Frequency Stability	±25, ±50, ±100ppm	
Operating emperature	0-70°C, -20-70°C, -40-85°C	
Fan Out Type	HCMOS Square wave	
Load	15pF	15pF
Voltage Voh	4.5V Minimum	3.0V Minimum
Voltage Vol	0.4V Maximum	0.3V Maximum
Duty Cycle	40/60 Maximum	40/60 Maximum
Rise/Fall Time	5ns	5ns
Frequency Control	Positive Transfer Characteristic	
	Pullability	±50ppm, ±100ppm, ±150ppm, ±200ppm Minimum
	Control Voltage	0.5Vdc to 4.5Vdc
	Center Frequency	2.5 Vdc
	Monotonic Linearity	< ± 15%
	Input impedance	50 Kohms Normal
Supply Voltage	+5Vdc +/-5% or 3.3V +/-5%	+3.3V
Supply Current	60mA Max	40mA Max
Package	All metal, hermetically sealed welded package	

*Please consult our sales representative for other specifications.

Dimension(mm)

Full Size VCXO

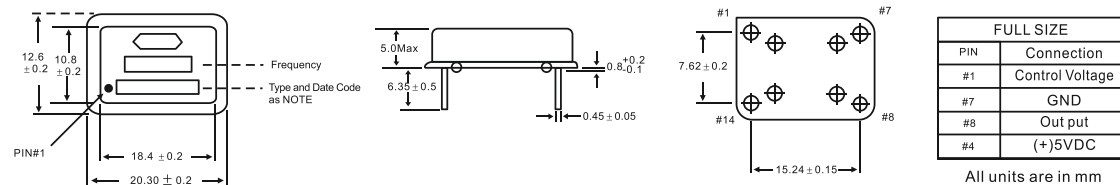

Haif Size VCXO

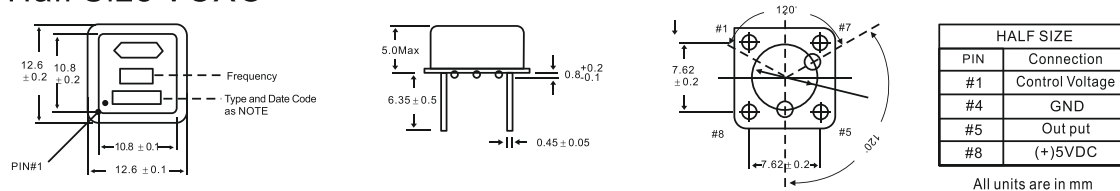

14 X9 mm High Frequency Very Low Noise/Low g-Sensitivity VCXO

Feature

- Typical 14 x 9 x 3.6mm SMD package
- High frequency high performance VCXO
- High frequency and very low phase noise/Low g-Sensitivity
- Low Power Consumption

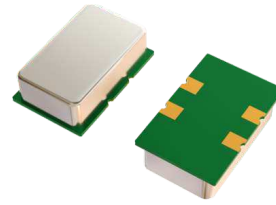

Electrical Specifications

Parameter	5.0V		3.3V		Unit	
	Min.	Max.	Min.	Max.		
Supply Voltage Variation(VDD)	4.75	5.25	3.135	3.465	V	
Frequency Range	50	125	50	125	MHz	
Frequency Stability (Overall)	-25	+25	-25	+25	ppm	
Standard Frequency	100,122.88,125				MHz	
Absolute Pulling Range (APR)	±30		±25	-	ppm	
Control Voltage Range	0	5.0	0	3.3	V	
Waveform	Sine Wave		CMOS			
Level (CMOS)	For CMOS		0.5		V	
			4.5			
Duty Cycle			45	55	%	
Transition Time: Rise/Fall Time +			3		nSec	
Load			15		pF	
Level(Sine Wave)	10		For Sine Wave		dbm	
Load	50				ohms	
Harmonics					dBc	
Current			30		mA	
Phase Noise @122.88MHz	100 Hz	-117			dBc/HZ	
	1kHz	-144				
	10kHz	-165				
	100kHz	-172				
	1MHz	-175				
Operating Temperature Range	-20°C ~ +70°C or -40°C ~ +85°C				°C	
Storage Temp. Range	-45	90	-45	90	°C	

Dimension(mm)

TOP VIEW

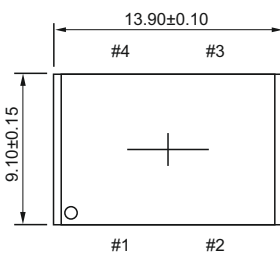

BOTTOM VIEW

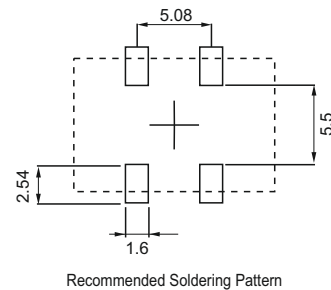
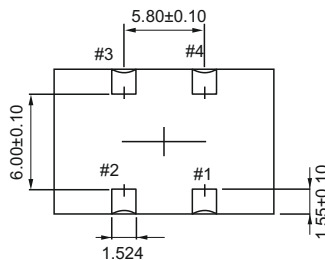

SIDE VIEW

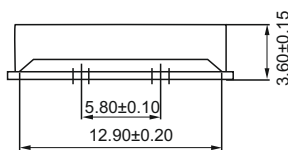

Pin	Function
#1	Vcon
#2	GND
#3	Output
#4	VDD

2.0 x 1.6 mm SMD Voltage Controlled Temperature Compensated Crystal Oscillator

Feature

- Typical 2.0 x 1.6 x 0.7 mm SMD package
- Compactness and lightweight
- VCTCXO available
- Miniature size and low profile

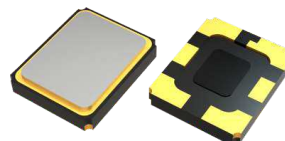

Electrical Specifications

Parameter	3.3/3.0/2.8V		2.5V		1.8V		Unit	
	Min.	Max.	Min.	Max.	Min.	Max.		
Supply Voltage Variation	2.66	3.465	2.375	2.625	1.71	1.89	V	
Frequency Range	10	52	10	52	10	52	MHz	
Standard Frequency	16.369,19.2,26,38.4						MHz	
Frequency Tolerance*	-	±2.0	-	±2.0	-	±2.0	ppm	
Frequency stability	VS Supply V(±5%) change	-	±0.2	-	±0.2	-	±0.2	ppm
	VS Load(±10%) change	-	±0.2	-	±0.2	-	±0.2	
	VS Aging(@1 st year)	-	±1.0	-	±1.0	-	±1.0	
Supply Current	10MHz ≅ FO<26MHz	-	1.5	-	1.5	-	1.5	mA
	26 MHz ≅ FO<52MHz	-	2.0	-	2.0	-	2.0	
Output Level (Clipped sine wave)	0.8	-	0.8	-	0.8	-	V _{p-p}	
Load	10KΩ//10pF		10KΩ//10pF		10KΩ//10pF			
Control Voltage Range(VCTCXO)	0.5	2.5	0.4	2.4	0.3	1.5	V	
Pulling Range (VCTCXO)	±5	-	±5	-	±5	-	ppm	
Vc Input Impedance(VCTCXO)	500	-	500	-	500	-	kΩ	
Phase Noise @19.2MHz	100Hz	-115		-115		-115		dBc/Hz
	1kHz	-135		-135		-135		
	10kHz	-148		-148		-148		
Start Time	-	2	-	2	-	2	mSec	
Storage Temp. Range	-55	125	-55	125	-55	125	°C	

Standard frequencies are frequencies which the crystal has been designed and does not imply a stock position

* Frequency at 25°C, 1 hour after reflow.

Dimension(mm)

TOP VIEW

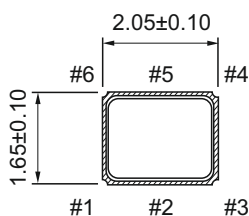

BOTTOM VIEW

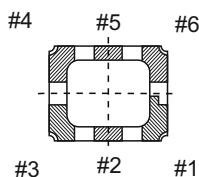

SIDE VIEW

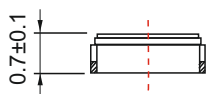

PIN#	Function
1	Vcon:VC-TCXO
2	GND:TCXO
3	No Connection
4	GND
5	Output
6	No Connection
6	VDD

Solder Pad Layout(mm)

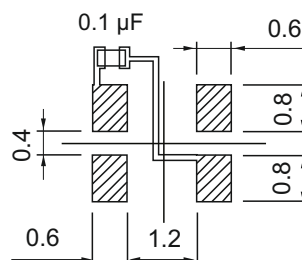

To ensure optimal oscillator performance, place a by-pass capacitor of 0.1 µF as close to the part as possible between Vdd and GND pads.

FREQ. STABILITY vs. TEMP. RANGE

Temp. (°C) \ ppm	±0.5	±1.0	±1.5	±2.0	±2.5
-20 ~ +70	o	o	o	o	o
-30 ~ +85	o	o	o	o	o
-40 ~ +85	o	o	o	o	o

o: Available Δ: Conditional X: Not available

2.5 x2.0 mm SMD Voltage Controlled Temperature Compensated Crystal Oscillator

Feature

- Typical 2.5 x 2.0 x 0.7 mm SMD package.
- Compactness and lightweight
- VCTCXO available
- Low thickness



Electrical Specifications

Parameter	3.3/3.0/2.8V		2.5V		1.8V		Unit	
	Min.	Max.	Min.	Max.	Min.	Max.		
Supply Voltage Variation	2.66	3.465	2.375	2.625	1.71	1.89	V	
Frequency Range	10	52	10	52	10	52	MHz	
Standard Frequency	16.369,19.2,26,38.4						MHz	
Frequency Tolerance*	-	±2.0	-	±2.0	-	±2.0	ppm	
Frequency stability	VS Supply V(±5%) change	-	±0.2	-	±0.2	-	±0.2	ppm
	VS Load(±10%) change	-	±0.2	-	±0.2	-	±0.2	
	VS Aging(@1 st year)	-	±1.0	-	±1.0	-	±1.0	
Supply Current	10MHz ≤ FO<26MHz	-	1.5	-	1.5	-	1.5	mA
	26 MHz ≤ FO<52MHz	-	2.0	-	2.0	-	2.0	
Output Level (Clipped sine wave)	0.8	-	0.8	-	0.8	-	V _{p-p}	
Load	10kΩ//10pF		10kΩ//10pF		10kΩ//10pF			
Control Voltage Range(VCTCXO)	0.5	2.5	0.4	2.4	0.3	1.5	V	
Pulling Range (VCTCXO)	±5	-	±5	-	±5	-	ppm	
Vc Input Impedance(VCTCXO)	500	-	500	-	500	-	kΩ	
Phase Noise @19.2MHz	100Hz	-115		-115		-115		dBc/Hz
	1kHz	-135		-135		-135		
	10kHz	-148		-148		-148		
Start Time	-	2	-	2	-	2	mSec	
Storage Temp. Range	-55	125	-55	125	-55	125	°C	

Standard frequencies are frequencies which the crystal has been designed and does not imply a stock position

*. Frequency at 25°C, 1 hour after reflow.

Dimension(mm)

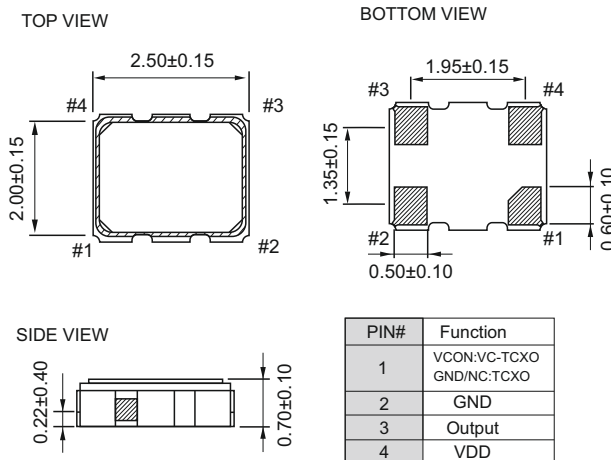

Solder Pad Layout(mm)

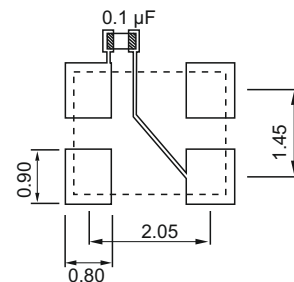

To ensure optimal oscillator performance, place a by-pass capacitor of 0.1 μF as close to the part as possible between Vdd and GND pads.

FREQ. STABILITY vs. TEMP. RANGE

ppm Temp. (°C)	±0.5	±1.0	±1.5	±2.0	±2.5
-20 ~ +70	○	○	○	○	○
-30 ~ +85	○	○	○	○	○
-40 ~ +85	○	○	○	○	○

○: Available △: Conditional X: Not available

3.2 x2.5 mm SMD Voltage Controlled Temperature Compensated Crystal Oscillator

Feature

- Typical 3.2 x 2.5 x 0.9 mm SMD package
- Compactness and lightweight
- VCTCXO available
- Low thickness

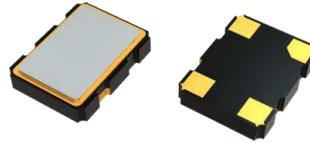

Electrical Specifications

Parameter	3.3/3.0/2.8V		2.5V		1.8V		Unit	
	Min.	Max.	Min.	Max.	Min.	Max.		
Supply Voltage Variation	2.66	3.465	2.375	2.625	1.71	1.89	V	
Frequency Range	10	52	10	52	10	52	MHz	
Standard Frequency	10,12.8,13,16.367667,16.368,16.369,19.2, 20,25,26,27,30,30.72,32,38.4							
Frequency Tolerance*	-	±2.0	-	±2.0	-	±2.0	ppm	
Frequency stability	VS Supply V(±5%) change	-	±0.2	-	±0.2	-	±0.2	ppm
	VS Load(±10%) change	-	±0.2	-	±0.2	-	±0.2	
	VS Aging(@1 st year)	-	±1.0	-	±1.0	-	±1.0	
Supply Current	10MHz ≦ FO<26MHz	-	1.5	-	1.5	-	1.5	mA
	26 MHz ≦ FO<52MHz	-	2.0	-	2.0	-	2.0	
Output Level (Clipped sine wave)	0.8	-	0.8	-	0.8	-	Vp-p	
Load	10KΩ//10pF		10KΩ//10pF		10KΩ//10pF			
Control Voltage Range(VCTCXO)	0.5	2.5	0.4	2.4	0.3	1.5	V	
Pulling Range (VCTCXO)	±5	-	±5	-	±5	-	ppm	
Vc Input Impedance(VCTCXO)	500	-	500	-	500	-	kΩ	
Phase Noise @19.2MHz	100Hz	-115		-115		-115		dBc/Hz
	1kHz	-135		-135		-135		
	10kHz	-148		-148		-148		
Start Time	-	2	-	2	-	2	mSec	
Storage Temp. Range	-55	125	-55	125	-55	125	°C	

Standard frequencies are frequencies which the crystal has been designed and does not imply a stock position

* Frequency at 25°C, 1 hour after reflow.

Dimension(mm)

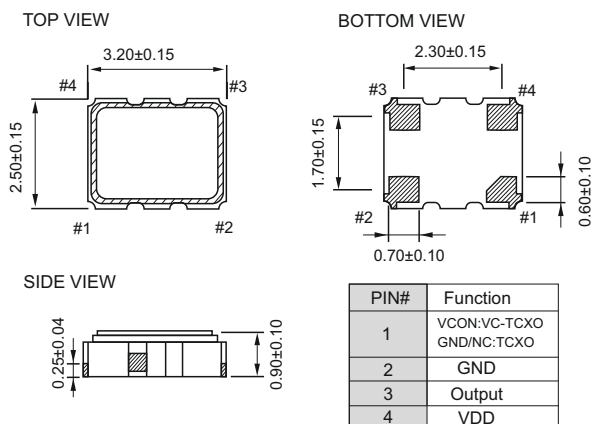

Solder Pad Layout(mm)

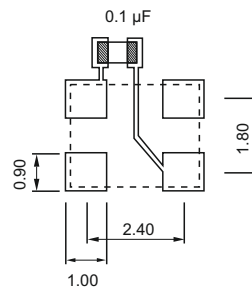

To ensure optimal oscillator performance, place a by-pass capacitor of 0.1 µF as close to the part as possible between Vdd and GND pads.

FREQ. STABILITY vs. TEMP. RANGE

ppm / Temp. (°C)	±0.5	±1.0	±1.5	±2.0	±2.5
-20 ~ +70	○	○	○	○	○
-30 ~ +85	○	○	○	○	○
-40 ~ +85	○	○	○	○	○

○: Available Δ :Conditional X: Not available

5.0 x3.2 mm SMD Voltage Controlled Temperature Compensated Crystal Oscillator

Feature

- Typical 5.0 x 3.2 x 1.1 mm SMD package
- CMOS and Clipped Sine Wave output optional
- Compactness and lightweight
- Voltage control TCXO available

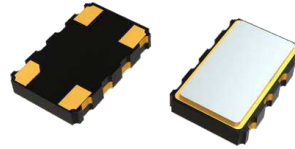

Electrical Specifications

Parameter	3.3/3.0/2.8V		2.5V		1.8V		Unit	
	Min.	Max.	Min.	Max.	Min.	Max.		
Supply Voltage Variation	2.66	3.465	2.375	2.625	1.71	1.89	V	
Frequency Range	10	52	10	52	10	52	MHz	
Standard Frequency	10,12.8,13,16.368,16.369,19.2,19.44,20,25,26,27,30,30.72,32,38.4						MHz	
Frequency Tolerance*	-	±2.0	-	±2.0	-	±2.0	ppm	
Frequency stability	VS Supply V(±5%) change	-	±0.2	-	±0.2	-	±0.2	ppm
	VS Load(±10%) change	-	±0.2	-	±0.2	-	±0.2	
	VS Aging(@1 st year)	-	±1.0	-	±1.0	-	±1.0	
Supply Current (Clipped Sine)	10MHz ≦ FO<26MHz	-	1.5	-	1.5	-	1.5	mA
	26 MHz ≦ FO<52MHz	-	2.0	-	2.0	-	2.0	
Supply Current(CMOS) 10MHz ≦ FO<52MHz	-	10	-	5	-	7	mA	
Clipped sine wave	Output Level	0.8	-	0.8	-	0.8	-	V _{p-p}
	Load	10kΩ//10pF		10kΩ//10pF		10kΩ//10pF		
CMOS	Output High	0.9V _{DD}	-	0.9V _{DD}	-	0.9V _{DD}	-	V
	Output Low	-	0.1V _{DD}	-	0.1V _{DD}	-	0.1V _{DD}	V
	Load	-	15	-	15	-	15	pF
Control Voltage Range(VCTCXO)	0.5	2.5	0.4	2.4	0.3	1.5	V	
Pulling Range (VCTCXO)	±5	-	±5	-	±5	-	ppm	
Vc Input Impedance(VCTCXO)	500	-	500	-	500	-	kΩ	
Phase Noise @19.2MHz	100Hz	-115		-115		-115		dBc/Hz
	1kHz	-135		-135		-135		
	10kHz	-148		-148		-148		
Start Time	-	2	-	2	-	2	mSec	
Storage Temp. Range	-55	125	-55	125	-55	125	°C	

Standard frequencies are frequencies which the crystal has been designed and does not imply a stock position

* Frequency at 25°C, 1 hour after reflow.

Dimension(mm)

TOP VIEW

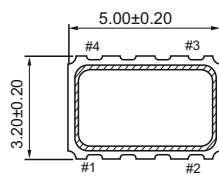

BOTTOM VIEW

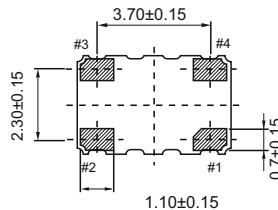

SIDE VIEW

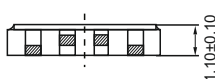

PIN#	Function
1	VCON:VC-TCXO GND/NC:TCXO
2	GND
3	Output
4	VDD

Solder Pad Layout(mm)

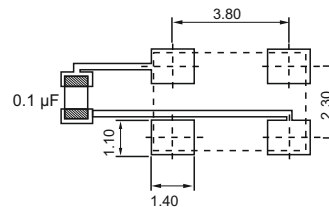

To ensure optimal oscillator performance, place a by-pass capacitor of 0.1 μF as close to the part as possible between Vdd and GND pads.

FREQ. STABILITY vs. TEMP. RANGE

Temp. (°C)	ppm				
	±0.5	±1.0	±1.5	±2.0	±2.5
-20 ~ +70	○	○	○	○	○
-30 ~ +85	○	○	○	○	○
-40 ~ +85	○	○	○	○	○

○: Available Δ: Conditional X: Not available

7.0 x5.0 mm SMD Voltage Controlled Temperature Compensated Crystal Oscillator

Feature

- Typical 7.0 x 5.0 x 1.9 mm ceramic package
- Compactness and light weight
- Low power consumption
- VCTCXO available

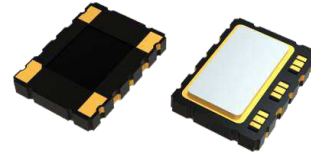

Electrical Specifications

Parameter	3.3/3.0		2.5V		Unit
	Min.	Max.	Min.	Max.	
Supply Voltage Variation	$V_{DD}-5\%$	$V_{DD}+5\%$	$V_{DD}-5\%$	$V_{DD}+5\%$	V
Frequency Range	5	52	5	52	MHz
Standard Frequency	5,6,4,8,8.192,10,12.5,12.8,16,16.384,19.44,25,26				MHz
Frequency Tolerance*	-	±2.0	-	±2.0	ppm
Frequency stability	VS Supply V(±5%) change	±0.1	-	±0.1	ppm
	VS Load(±10%) change	±0.2	-	±0.2	
	VS Aging(@1 st year)	±1.0	-	±1.0	
Supply Current(Clipped Sine)	-	3.5	-	3.5	mA
Supply Current(CMOS)	-	6	-	6	mA
Clipped sine wave	Output Level	0.8	-	0.8	V_{P-P}
	Load	10KΩ//10pF		10KΩ//10pF	
CMOS	Output High	0.9V _{DD}	-	0.9V _{DD}	V
	Output Low	-	0.1V _{DD}	-	V
	Load	15		15	
	Duty	45	55	45	55
Control Voltage Range(VCTCXO)	0.5	2.5	0.4	2.4	V
Pulling Range (VCTCXO)	±5	±12	±5	±12	ppm
Vc Input Impedance(VCTCXO)	100	-	100	-	kΩ
Phase Noise @19.2MHz Clipped Sine	100Hz	-115		-115	
	1kHz	-135		-135	
	10kHz	-148		-148	
Start Time	-	2	-	2	mSec
Storage Temp. Range	-55	125	-55	125	°C

Standard frequencies are frequencies which the crystal has been designed and does not imply a stock position

* Frequency at 25°C, 1 hour after reflow.

Dimension(mm)

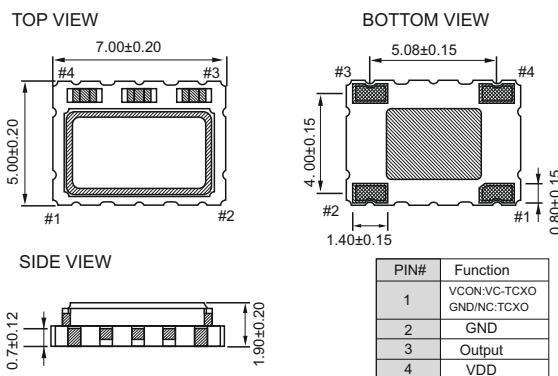

Solder Pad Layout(mm)

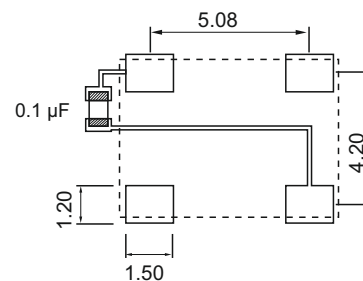

To ensure optimal oscillator performance, place a by-pass capacitor of 0.1 μF as close to the part as possible between Vdd and GND pads.

FREQ. STABILITY vs. TEMP. RANGE

Temp. (°C)	ppm	±0.5	±1.0
-20 ~ +70		○	○
-30 ~ +85		○	○
-40 ~ +85		○	○

○: Available △ :Conditional X: Not available

14.3 x8.7mm SMD Voltage Controlled Temperature Compensated Crystal Oscillator

Feature

- Typical 14.3 x 8.7 x 4.9 mm
- Metal cover, FR-4 PCB based.
- Output: TTL/CMOS or Clipped Sine Wave
- Low current option (2mA or Clipped Sine Wave o/p)
- VCTCXO available

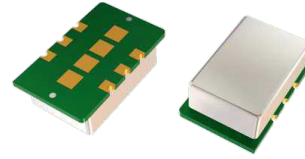

Electrical Specifications

Parameter	3.3/3.0		5.0V		Unit
	Min.	Max.	Min.	Max.	
Supply Voltage Variation	$V_{DD}-5\%$	$V_{DD}+5\%$	$V_{DD}-5\%$	$V_{DD}+5\%$	V
Frequency Range	5	40	5	40	MHz
Standard Frequency (for CMOS)	5, 6.4, 8, 8.192, 10, 12.5, 12.8, 16, 16.384, 19.44, 20, 25				MHz
Standard Frequency (for Clipped Sine)	8.192, 10, 12.5, 12.8, 16, 16.384, 19.44, 20, 25				MHz
Frequency Tolerance*	-	±2.0	-	±2.0	ppm
Frequency stability	VS Supply V(±5%) change	±0.2	-	±0.2	ppm
	VS Load(±10%) change	±0.2	-	±0.2	
	VS Aging(@1 st year)	±1.0	-	±1.0	
Supply Current(Clipped Sine)	-	3.5	-	3.5	mA
Supply Current(CMOS)	-	6	-	6	mA
Clipped sine wave	Output Level	0.8	-	0.8	V_{p-p}
	Load	10kΩ//10pF		10kΩ//10pF	
CMOS	Output High	$0.9V_{DD}$	-	$0.9V_{DD}$	V
	Output Low	-	$0.1V_{DD}$	-	V
	Load	15		15	
	Duty	45	55	45	55
Control Voltage Range(VCTCXO)	0.5	2.5	0.5	2.5	V
Pulling Range (VCTCXO)	±5	-	±5	-	ppm
Vc Input Impedance(VCTCXO)	100	-	100	-	kΩ
Phase Noise @12.8MHz	100Hz	-120		-120	
	1kHz	-140		-140	
	10kHz	-148		-148	
Start Time	-	2	-	2	mSec
Tri-State(option)	Disable	-	0.99	-	1.5
	Enable	2.31	-	3.5	-
Storage Temp. Range	-55	125	-55	125	°C

Standard frequencies are frequencies which the crystal has been designed and does not imply a stock position

* Frequency at 25°C, 1 hour after reflow.

Dimension(mm)

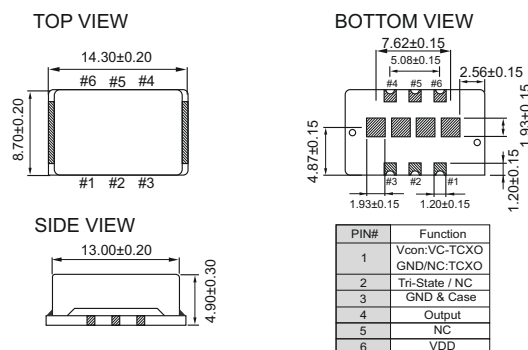

Solder Pad Layout(mm)

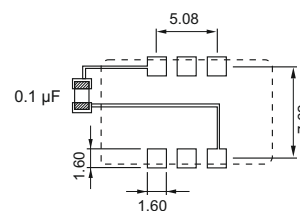

To ensure optimal oscillator performance, place a by-pass capacitor of 0.1 µF as close to the part as possible between Vdd and GND pads.

FREQ. STABILITY vs. TEMP. RANGE

Temp. (°C) \ ppm	±0.05	±0.1	±0.14	±0.2	±0.28	±0.37	±0.5
-10 ~ +60	o	o	o	o	o	o	o
-20 ~ +70	o	o	o	o	o	o	o
-40 ~ +85	X	X	X	Δ	o	o	o

o: Available Δ: Conditional X: Not available

3.2x2.5mm High Frequency Temperature Compensated Crystal Oscillator

Feature

- Low power supply voltage: 3.3V and 2.5V options
- Clock output: CMOS, LVPECL, LVDS options
- CMOS output frequency support from 10MHz TO 250MHz
- Differential output frequency supports from 10MHz to 1.5GHz
- Low Phase Jitter typical 0.8 pS RMS at 12kHz to 20MHz frequency offsets
- Low current consumption, Pbfree/RoHS compliant
- Frequency Stability ± 2.0 ppm over -40°C to 85°C

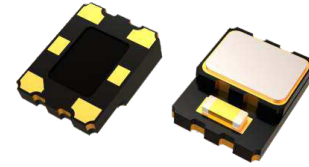

Electrical Specifications

Parameter	LVPECL		LVDS		CMOS		Unit
	Min.	Max.	Min.	Max.	Min.	Max.	
Supply Voltage	3.3V or 2.5V						V
Supply Voltage Variation	V _{DD} -5%	V _{DD} +5%	V _{DD} -5%	V _{DD} +5%	V _{DD} -5%	V _{DD} +5%	V
Frequency Range	10	1500	10	1500	10	250	MHz
Supply Current	-	54	-	45	-	40	mA
Output Level	Output High	V _{DD} -1.03	V _{DD} -0.6	-	1.6	90%V _{DD}	V
	Output Low	V _{DD} -1.85	V _{DD} -1.6	0.9	-	10%V _{DD}	V
Transition Time(Rise/ Fall Time)	-	0.5(20-80%)	-	1.0(20-80%)	-	3.0(20-80%)	nSec
Duty Cycle	45	55	45	55	45	55	%
Start time	-	5	-	5	-	5	mSec
Tri-State mode (input to pin 2)	Enable	70%V _{DD}	-	70%V _{DD}	-	70%V _{DD}	-
	Disable	-	30%V _{DD}	-	30%V _{DD}	-	30%V _{DD}
Stand by Current	-	20	-	20	-	20	mA
Output Loading	50 Ω into V _{DD} -2V		100 Ω		15pF		
Phase Noise	Typ.	Max.	Typ.	Max.	Typ.	Max.	dBc/Hz
	At V _{DD} =3.3V, F _{out} =250MHz						
1kHz offset	-107	-	-107	-	-107	-	
	10kHz offset	-111	-	-111	-	-111	
	100kHz offset	-114	-	-114	-	-114	
	1MHz offset	-125	-	-125	-	-125	
	20MHz offset	-147	-	-147	-	-147	
RMS Phase Jitter(12kHz to 20MHz)	0.8	1.5	0.8	1.5	0.8	1.5	pSec

Dimension(mm)

PIN Assignments

Solder Pad Layout(mm)

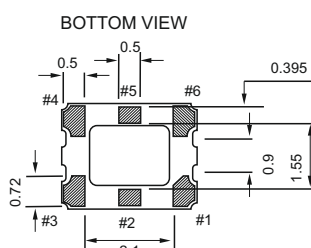
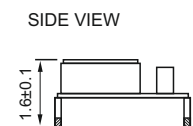
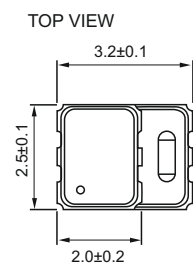

Type	CMOS	Differential
Pad	Function	Function
1	No Connection	No Connection
2	Tri-State	Tri-State
3	GND	
4	Output	Output
5	No Connection	Comp. Output
6	Supply Voltage(V _{DD})	

(LVPECL LVDS)

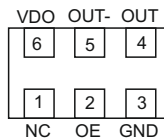

(CMOS)

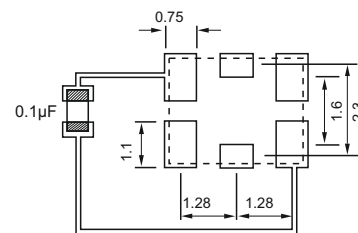
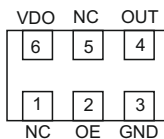

To ensure optimal oscillator performance, place a by-pass capacitor of 0.1 μF as close to the part as possible between V_{DD} and GND pads.

FREQ. STABILITY vs. TEMP. RANGE

Temp. ($^{\circ}\text{C}$)	ppm		
	± 1.0	± 2.0	± 2.5
-30 ~ +85	○	○	○
-40 ~ +85	△	○	○

Inclusive of calibration @ 25°C , operating temperature load variation, aging (1st year), shock, and vibration

5.0 x 3.2 mm SMD High Precision VCTCXO Crystal Oscillator

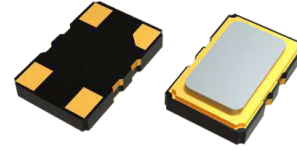

Feature

- Typical 5.0 x 3.2 x 1.55 mm ceramic SMD package.
- ± 0.28 ppm, $-40^{\circ}\text{C} \sim +85^{\circ}\text{C}$; ± 0.05 ppm, $-10^{\circ}\text{C} \sim +70^{\circ}\text{C}$
- CMOS and Clipped Sine wave (without DC-cut capacitor) output optional

Electrical Specifications

Parameter		5.0V		3.3V		Unit
		Min.	Max.	Min.	Max.	
Supply Voltage Variation		VDD-5%	VDD+5%	VDD-5%	VDD+5%	V
Frequency Range		10	52	10	52	MHz
Standard Frequency		10,12.8,13,19.2,20,25,26,30.72				MHz
Frequency Tolerance*		-	± 2.0	-	± 2.0	ppm
Frequency stability	Vs Supply Voltage($\pm 5\%$) change	-	± 0.3	-	± 0.3	ppm
	Vs Load($\pm 10\%$) change	-	± 0.2	-	± 0.2	
	Vs Aging (@1st year)	-	± 0.1	-	± 0.1	
Supply Current	CMOS 10MHz \cong F0 \cong 40MHz	-	6	-	6	mA
	CMOS 40MHz $>$ F0 \cong 52MHz	-	8	-	8	
	Clipped Sine Wave	-	3.5	-	3.5	
Output Level (CMOS)	Output High	90% VDD	-	90% VDD	-	V
	Output Low	-	10% VDD	-	10% VDD	
	Duty	45	55	45	55	
Output Level (Clipped Sine Wave)		0.8	-	0.8	-	Vp-p
Load	CMOS	15pF		15pF		
	Clipped Sine Wave	10k Ω //10pF		10k Ω //10pF		
Control Voltage Range(VCTCXO)		0.5	2.5	0.5	2.5	V
Pulling Range (VCTCXO)		± 5	-	± 5	-	ppm
Vc Input Impedance(VCTCXO)		100	-	100	-	k Ω
Phase Noise @10.0MHz	100Hz	-125				dBc/Hz
	1kHz	-145				
	10kHz	-150				
Start Time		-	2	-	2	mSec
Storage Temp.Range		-55	125	-55	125	$^{\circ}\text{C}$

Standard frequencies are frequencies which the crystal has been designed and does not imply a stock position.
*Frequency at 25 $^{\circ}\text{C}$, 1 hour after reflow.

Dimension(mm)

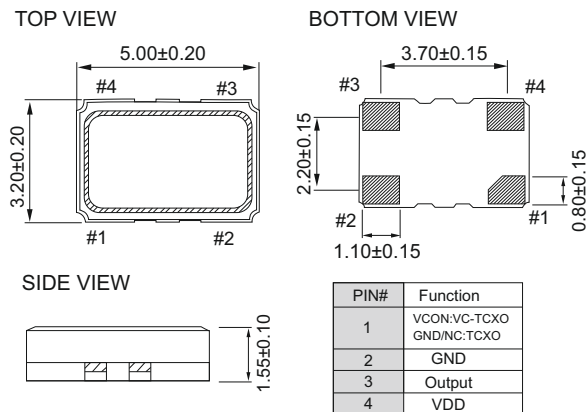

Solder Pad Layout(mm)

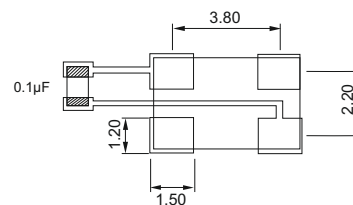

To ensure optimal oscillator performance, place a by-pass capacitor of 0.1 μF as close to the part as possible between Vdd and GND pads.

FREQ. STABILITY vs. TEMP. RANGE

ppm / Temp. ($^{\circ}\text{C}$)	± 0.05	± 0.1	± 0.2	± 0.28	± 0.5
-10 ~ +70	o	o	o	o	o
20 ~ +70	X	o	o	o	o
-40 ~ +85	X	X	Δ	o	o

o: Available Δ : Conditional X: Not available

7.0x5.0 mm SMD Voltage Controlled Temperature Compensated Crystal Oscillator **Aldinet**

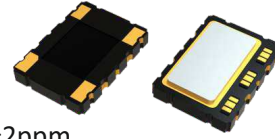

Feature

- Typical 7.0 x5.0 x1.9 mm ceramic SMD package
- High Precision for -40°C~+85°C, ±0.28ppm, -40°C~+105°C, ±2ppm
- CMOS and Clipped Sine wave(without DC-cut capacitor)output optional

Electrical Specifications

Parameter	5.0V		3.3V		Unit	
	Min.	Max.	Min.	Max.		
Supply Voltage Variation	VDD-5%	VDD+5%	VDD-5%	VDD+5%	V	
Frequency Range	5	52	5	52	MHz	
Standard Frequency	10,12.8,16.384,19.2,19.44,20,25,26				MHz	
Frequency Tolerance*	-	±2.0	-	±2.0	ppm	
Frequency stability	VS Supply V(±5%) change	±0.1	-	±0.05	ppm	
	VS Load(±10%) change	±0.05	-	±0.05		
	VS Aging(@1 st year)	±1.0	-	±1.0		
Supply Current	CMOS output	6	-	6	mA	
	Clipped Sine Wave	3.5	-	3.5		
Output Level (CMOS)	Output High	90% VDD	-	90% VDD	V	
	Output Low	10% VDD	-	10% VDD		
	Duty	45	55	45		55
Output Level (Clipped Sine Wave)	0.8	-	0.8	-	Vp-p	
Load	CMOS	15pF		15pF		
	Clipped Sine Wave	10KΩ//10pF		10KΩ//10pF		
Control Voltage Range(VCTCXO)	0.5	2.5	0.5	2.5	V	
Pulling Range (VCTCXO)	±5	-	±5	-	ppm	
Vc Input Impedance(VCTCXO)	100	-	100	-	kΩ	
Phase Noise @10.0MHz	100Hz	-130		-130		dBc/Hz
	1kHz	-145		-145		
	10kHz	-154		-154		
Start Time	-	2	-	2	mSec	
Storage Temp. Range	-55	125	-55	125	°C	

Standard frequencies are frequencies which the crystal has been designed and does not imply a stock position
 . * Frequency at 25°C, 1 hour after reflow.

Dimension(mm)

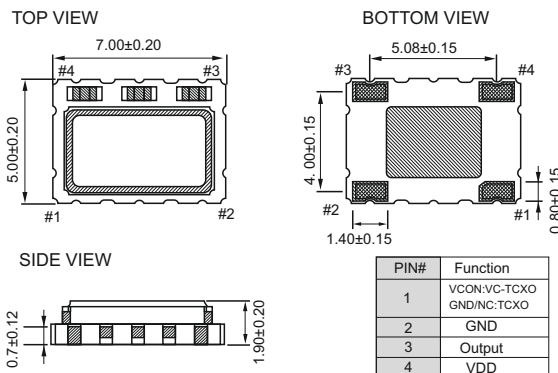

Solder Pad Layout(mm)

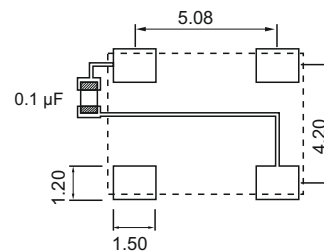

To ensure optimal oscillator performance, place a by-pass capacitor of 0.1 μF as close to the part as possible between Vdd and GND pads.

FREQ. STABILITY vs. TEMP. RANGE

Temp. (°C) \ ppm	±0.05	±0.1	±0.14	±0.2	±0.28	±0.5	±2
-10 ~ +70	○	○	○	○	○	○	○
-20 ~ +70	X	○	○	○	○	○	○
-40 ~ +85	X	X	X	△	○	○	○
-40 ~ +95	X	X	X	X	X	△	○
-40 ~ +105	X	X	X	X	X	X	○

○: Available △:Conditional X: Not available

7.0x5.0mm SMD Voltage Controlled Temperature Compensated Crystal Oscillator

Feature

- Typical 7.0 x 5.0 x 1.9 mm SMD package
- Stratum 3 (Overall ±4.6ppm including 20 years aging)
- CMOS and Clipped Sine wave (without DC-cut capacitor) output optional

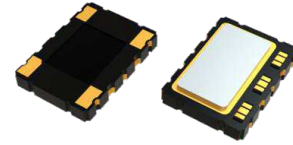

Electrical Specifications

Parameter	5.0V		3.3V		Unit
	Min.	Max.	Min.	Max.	
Supply Voltage Variation	VDD-5%	VDD+5%	VDD-5%	VDD+5%	V
Frequency Range	5	52	5	52	MHz
Standard Frequency	10,12.8,16,384,19.2,19.44,20,25,26				MHz
Operating Temp. Range	-20~+70 / -40~+85				°C
Frequency stability (Overall, 20 Years)*	-	±4.6	-	±4.6	ppm
Frequency Stability Vs Temp. Range (Ref. to (FMAX+Fmin)/2)	-	±0.14 (-20~+70°C)	-	±0.14 (-20~+70°C)	ppm
	-	±0.28 (-40~+85°C)	-	±0.28 (-40~+85°C)	
Holdover Stability +	-	±0.32	-	±0.32	ppm
Supply Current	CMOS output	6	-	6	mA
	Clipped Sine Wave	3.5	-	3.5	
Output Level (CMOS)	Output High	90% VDD	-	90% VDD	V
	Output Low	10% VDD	-	10% VDD	
	Duty	45	55	45	
Output Level (Clipped Sine Wave)	0.8	-	0.8	-	Vp-p
Load	CMOS	15pF		15pF	
	Clipped Sine Wave	10kΩ//10pF		10kΩ//10pF	
Control Voltage Range(VCTCXO)	0.5	2.5	0.5	2.5	V
Pulling Range (VCTCXO)	±5	-	±5	-	ppm
Vc Input Impedance(VCTCXO)	100	-	100	-	kΩ
Phase Noise @10.0MHz	100Hz	-130			dBc/Hz
	1kHz	-145			
	10kHz	-154			
Start Time	-	2	-	2	mSec
Storage Temp. Range	-55	125	-55	125	°C

Standard frequencies are frequencies which the crystal has been designed and does not imply a stock position.

* Including calibration @ 25°C, supply voltage VDD ±5%, load ±10%, reflow soldering, 20 years aging and frequency stability over temperature.

+ Including 24hours aging , supply voltage VDD ±5% and frequency stability over temperature.

Dimension(mm)

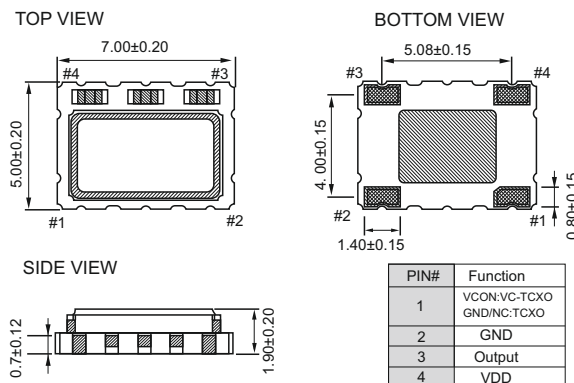

Solder Pad Layout(mm)

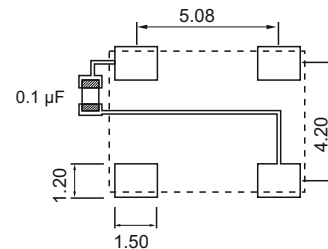

To ensure optimal oscillator performance, place a by-pass capacitor of 0.1 µF as close to the part as possible between Vdd and GND pads.

7.0 x5.0 mm SMD Voltage Controlled Temperature Compensated Crystal Oscillator

Feature

- Typical 7.0 x 5.0 x 1.9 mm SMD package
- High Precision and High Temperature for -40 ~ +95°C ±0.1ppm, -40 ~ +105°C, ±0.2ppm
- CMOS and Clipped Sine wave (without DC-cut capacitor) output optional

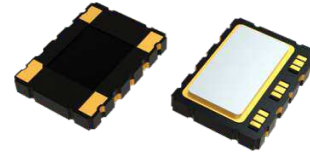

Electrical Specifications

Parameter	3.3V		2.5V		Unit
	Min.	Max.	Min.	Max.	
Supply Voltage Variation	V _{DD} -5%	V _{DD} +5%	V _{DD} -5%	V _{DD} +5%	V
Frequency Range	10	52	10	52	MHz
Standard Frequency	10,19,2,20				MHz
Frequency Tolerance*	-	±1.5	-	±1.5	ppm
Frequency stability	VS Supply V(±5%) change	±0.1	-	±0.05	ppm
	VS Load(±10%) change	±0.05	-	±0.05	
	VS Aging(@1 st year)	±1.0	-	±1.0	ppm/year
Supply Current (Clipped Sine Wave)	-	5.0	-	4.5	mA
Supply Current (CMOS output)	-	7.5	-	7	mA
Load	CMOS	15pF			
	(Clipped Sine Wave)	10kΩ//10pF			
Output Level CMOS	Output High	0.9V _{DD}	-	0.9V _{DD}	V
	Output Low	-	0.1V _{DD}	0.1V _{DD}	V
	Duty	45	55	45	55
Control Voltage Range(VCTCXO)	0.5	2.5	0.5	2.5	V
Pulling Range (VCTCXO)	±5	-	±5	-	ppm
Vc Input Impedance(VCTCXO)	100	-	100	-	kΩ
Phase Noise @20MHz	100Hz	-130			dBc/Hz
	1kHz	-148			
	10kHz	-156			
Start Time	-	2	-	2	mSec
Storage Temp.Range	-55	125	-55	125	°C

Standard frequencies are frequencies which the crystal has been designed and does not imply a stock position

* Frequency at 25°C, 1 hour after reflow.

Dimension(mm)

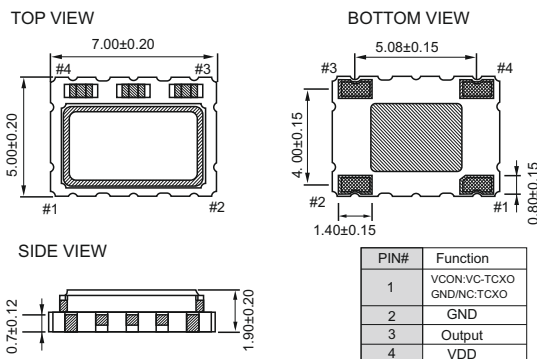

Solder Pad Layout(mm)

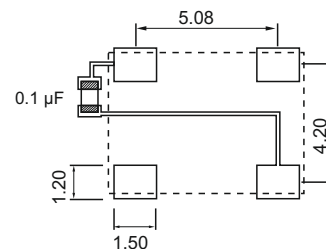

To ensure optimal oscillator performance, place a by-pass capacitor of 0.1 µF as close to the part as possible between V_{DD} and GND pads.

FREQ. STABILITY vs. TEMP. RANGE

Temp. (°C) \ ppm	±0.05	±0.1	±0.2	±0.28	±0.5	±2
-40 ~ +85	△	○	○	○	○	○
-40 ~ +95	△	△	○	○	○	○
-40 ~ +105	X	△	○	○	○	○

○: Available △: Conditional X: Not available

20.4 x12.8mm DIP Voltage Controlled Temperature Compensated Crystal Oscillator

Feature

- Typical 20.4 x12.8 x 7.8 mm
- Hermetically Sealed 14 PIN DIP Package
- Double sealed metal case and high reliability
- VCTCXO available



Electrical Specifications

Parameter	Clipped Sine Wave				CMOS				Unit	
	3.3V		2.8V		3.3V		2.8V			
	Min.	Max.	Min.	Max.	Min.	Max.	Min.	Max.		
Supply Voltage Variation(V _{DD}) ±5%	3.135	3.465	2.66	2.94	3.135	3.465	2.66	2.94	V	
Frequency Range	10	52	10	52	1.25	52	1.25	52	MHz	
Frequency Tolerance*	-	±2.0	-	±2.0	-	±2.0	-	±2.0	ppm	
Frequency stability	VS Supply V(±5%) change	-	±0.2	-	±0.2	-	±0.2	-	±0.2	ppm
	VS Load(±10%) change	-	±0.2	-	±0.2	-	±0.2	-	±0.2	
	VS Aging(@1 st year)	-	±1.0	-	±1.0	-	±1.0	-	±1.0	
Supply Current	10MHz ≡ FO<15MHz	-	2.0	-	2.0	Only for clipped sine wave				mA
	15 MHz ≡ FO<26MHz	-	3.0	-	3.0					
	26 MHz ≡ FO<52MHz	-	4.0	-	4.0					
Output Level	0.8	-	0.8	-					V _{p-p}	
Supply Current	1.25MHz ≡ FO<10MHz	Only for CMOS				-	10	-	7	mA
	10MHz ≡ FO<15MHz					-	15	-	10	
	15 MHz ≡ FO<26MHz					-	20	-	15	
	26 MHz ≡ FO<52MHz					-	25	-	20	
CMOS	Output High					0.9V _{dd}	-	0.9V _{dd}	-	V
	Output Low					-	0.1V _{dd}	-	0.1V _{dd}	
	Duty					40	60	40	60	
Control Voltage Range(VCTCXO)	0.5	2.5	0.5	2.5	0.5	2.5	0.5	2.5	V	
Pulling Range (VCTCXO)	±5		±5		±5		±5		ppm	
Vc Input Impedance(VCTCXO)	100	-	100	-	100	-	100	-	kΩ	
Phase Noise @13MHz	100Hz	-115		-115		-115		-120		dBc/Hz
	1kHz	-135		-135		-135		-140		
	10kHz	-148		-148		-148		-148		
Start Time	-	2	-	2	-	2	-	2	mSec	
Storage Temp. Range	-55	125	-55	125	-55	125	-55	125	°C	

Standard frequencies are frequencies which the crystal has been designed and does not imply a stock position
 *. Frequency at 25°C, 1 hour after reflow.

Dimension(mm)

TOP VIEW

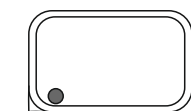

PIN 1 Symbol

BOTTOM VIEW

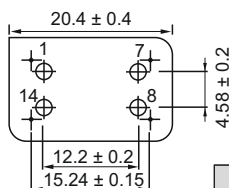

SIDE VIEW

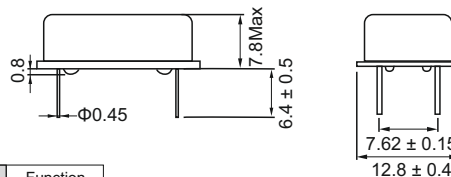

Recommended soldering pattern

PIN#	Function
1	Vcon / NC
7	GND
8	Output
14	VDD

FREQ. STABILITY vs. TEMP. RANGE

Temp. (°C)	ppm		Clipped sine wave		CMOS	
	±0.5	±1.0	±0.5	±1.0	±0.5	±1.0
-20 ~ +70	○	○	○	○	○	○
-40 ~ +85	△	○	△	○	○	○

○: Available △: Conditional X: Not available
 " Pulling Range < 10 ppm available

18.5x12 mm to 91x56 mm DIP Temperature Compensated Crystal Oscillator

Feature

- Mobile communication, Avionics, Test Equipment, Electronic instruments



Electrical Specifications

Items	TFT210	TFT230	TFT250	TFT270	TFT300
Frequency Range(MHz)	1~32	30~95	90~155	150~210	200~1500
F-T stability(ppm)	±0.5~±5			±1~±10	
Operating emperature(°C)	-10~60 0~70 -20~+70 -40~+70 -50~+85				
Storage Temperature(°C)	-55~+120				
Power	Voltage(Vdc)	+3.3 +5.0 +12			
	Current(mA)	2~20			
Output	Waveform	Sine/Pulse		Sine	
	Impedance	50Ω /100Ω		50Ω	
	Level	(Pulse):TTL/HCMOS		(Sine):≥1.5vP-P/50Ω	
	Type	(pins):SMA		SMA	
Aging/Year(ppm)	±1 ~ ±3				
Frequency trim(ppm)	±1 ~ ±5/(mechanical or electrical)				
F-V Stability	(3~5)x10 - 7(3.3V ± 5%, 5V ± 10%, 12V ± 10%)				
Dimension(mm)	18.5x12x(8~10) 20.8x13.2x(8~10) 25x15x10 30x20x10 40x25x15 44x27x19 50.8x50.8x18 91x56x20				

*Please consult our sales representati e for other specificacations.

Dimension(mm)

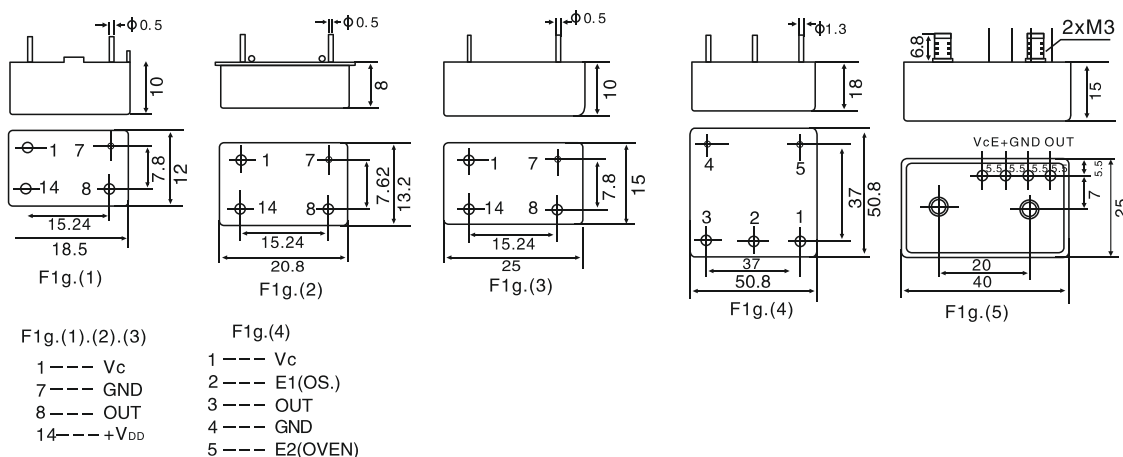

9.7 x 7.5mm Oven Controlled Crystal Oscillator

Feature

- Dimension 9.7 x 7.5 x 4.1mm, miniaturized 4-Pad SMD package
- ±20 ppb stability over -40 to +85°C
- Stratum 3 (Overall ±4.6 ppm including 20 years aging)
- Low power consumption and high reliability

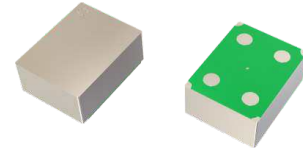

Electrical Specifications

Parameter	Min.	Type	Max.	Unit	
OUTPUT (PIN = "R.F. OUTPUT")					
Frequency	10		40	MHz	
Output Level:	Output High	2.4		V	
	Output Low		0.4	V	
Waveform:	Rectangular/ Clipped Sine				
Load(Rectangular/ Clipped sine)	15pF / 10K ohm//10pF			pF	
Duty(Rectangular)	45	50	55	%	
Frequency stability					
Frequency stability	Ambient (-20~+70°C / -40~+85°C)	±5, ±10, ±20, ±30, ±50		ppb	
	Daily	-3.0		+3.0	ppb
	Yearly	-0.6		+0.6	ppm
	10 Years	-3.0		+3.0	ppm
	Voltage(±5% change)	-5.0		+5.0	ppb
	Load(±5% change)	-5.0		+5.0	ppb
	Warm-up	-100		+100	ppb
Phase Noise	10Hz		-98	dBc/Hz	
	100Hz		-126		
	1kHz		-145		
	10kHz		-150		
ELECTRICAL FREQUENCY ADJUSTMENT (PIN = "VCO INPUT")					
Tuning Range	VCO @ 0 V		-5.0	ppm	
	VCO @ 3.3V	+5.0		ppm	
Control Voltage	0	1.65	3.3	V	
INPUT POWER (PIN = "+VDC")					
Voltage	3.135	3.3	3.465	V	
Current			350	mA	
Steady State		0.3	0.4	W	
Storage Temperature	-55		+125	°C	

Dimension(mm)

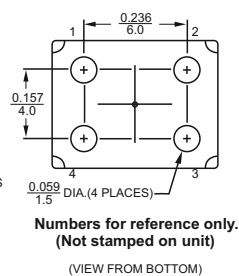
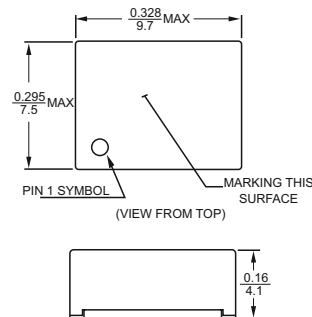

Solder Pad Layout(mm)

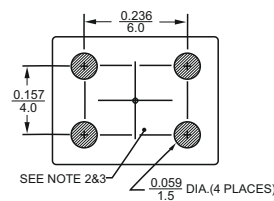

RECOMMENDED SOLDER PAD LAYOUT

Note 1. If the specification does not specify parameters for PIN 1 then PIN1 must remain unconnected.

Note 2. Copper in this area should be kept to a minimum to reduce heat loss from OCXO.

PIN CONNECTIONS	
PIN	FUNCTION
1 (See Note 1)	VCO INPUT OR NOT CONNECTED
2	0 VOLTS & CASE
3	R. F. OUTPUT
4	+VDC

Note 3. Bottom side reflow is forbidden unless specified in the oscillator specification.

Note 4. Aqueous cleaning is FORBIDDEN

Note 5. Test condition : A 0.1uF and 10uF X7R decoupling capacitor is required close to the unit.

14.3 x9.3 mm Oven Controlled Crystal Oscillator

Feature

- Dimension 14.3 x 9.3 x 6.5 mm typical
- 6-PIN SMD package
- Frequency Range , 10 MHz to 40MHz
- ±30 ppb stability over -40 to +85 °C
- Stratum 3 (Overall ±4.6 ppm including 20 years aging.)

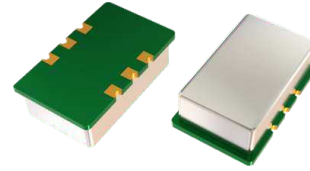

Electrical Specifications

Parameter	Min.	Type	Max.	Unit	
OUTPUT (PIN = "R.F. OUTPUT")					
Frequency	10		40	MHz	
Output Level:					
HCMOS	Output High	2.4		V	
	Output Low		0.4	V	
Waveform:	Rectangular				
Load	15			pF	
Duty(Rectangular)	45	50	55	%	
Frequency stability					
Frequency stability	Ambient (-20~+70°C / -40~+85°C)	±10, ±20, ±30, ±50			ppb
	Daily	-2.0		+2.0	ppb
	Yearly	-0.4		+0.4	ppm
	10 Years	-2.0		+2.0	ppm
	Voltage(±5% change)	-5.0		+5.0	ppb
	Load(±5% change)	-10.0		+10.0	ppb
	Warm-up	-0.1		+0.1	ppm
Phase Noise	10Hz	-98		-92	dBc/Hz
	100Hz	-126		-120	
	1kHz	-145		-140	
	10kHz	-152		-150	
ELECTRICAL FREQUENCY ADJUSTMENT (PIN = "VCO INPUT")					
Tuning Range	VCO @ 0 V			-5.0	ppm
	VCO @ 3.3V	+5.0			ppm
Control Voltage	0	1.65	3.3	V	
INPUT POWER (PIN = "+VDC")					
Voltage	3.135	3.3	3.465	V	
Current		500	600	mA	
Steady State		0.5	0.6	W	
Storage Temperature	-55		+125	°C	

Dimension(mm)

Solder Pad Layout(mm)

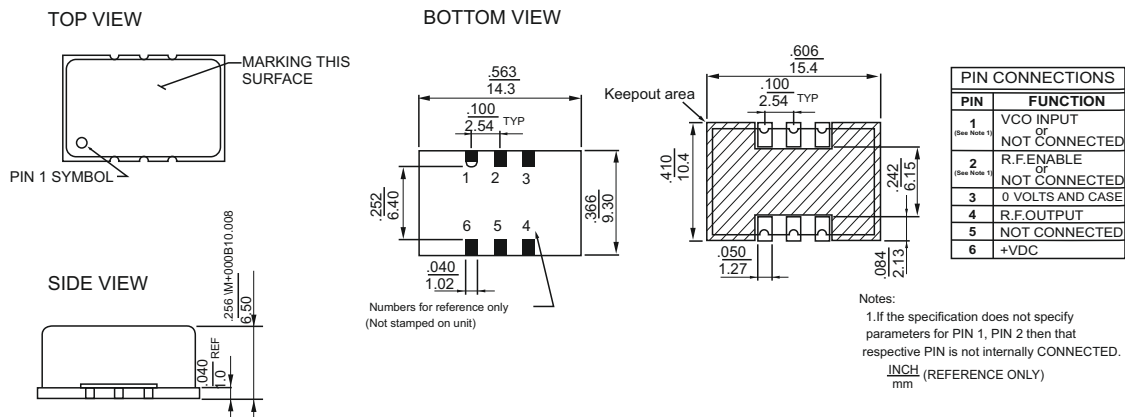

20.3 x12.7 mm Oven Controlled Crystal Oscillator



Feature

- Dimension 20.3 x 12.7 x 11.0 mm typical
- Stratum 3 (Overall ±4.6 ppm including 10 years aging.)

Electrical Specifications

Parameter	Min.	Type	Max.	Unit	
OUTPUT (PIN = "R.F. OUTPUT")					
Frequency	5	10	40	MHz	
Output Level:	Output High	2.4		V	
	Output Low		0.5	V	
Waveform:	Rectangular				
Load	15			pF	
Duty(Rectangular)	45	50	55	%	
Frequency stability					
Frequency stability	Ambient (0~+70°C/-30~+70°C /-40~+85°C)	±50,±100, ±200			ppb
	Daily	-5.0		+5.0	ppb
	Yearly	-0.5		+0.5	ppm
	10 Years	-3.0		+3.0	ppm
	Voltage(±5% change)	-50		+50	ppb
	Load(±5% change)	-50		+50	ppb
	Warm-up	-0.1		+0.1	ppm
	Aging	-5.0		+5.0	ppb
Phase Noise	10Hz			-105	dBc/Hz
	100Hz			-130	
	1kHz			-140	
	10kHz			-150	
ELECTRICAL FREQUENCY ADJUSTMENT (PIN = "VCO INPUT")					
Tuning Range	VCO @ 0 V			-5.0	ppm
	VCO @ 5.0V	+5.0			ppm
Control Voltage	0	2.5	5.0	V	
INPUT POWER (PIN = "+VDC")					
Voltage	4.75	5.0	5.25	V	
Current			400	mA	
Steady State			0.8	W	
Storage Temperature	-55		+125	°C	

Dimension(mm)

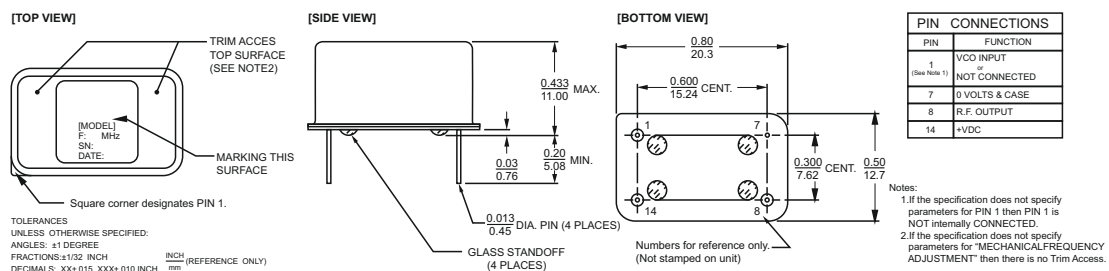

20.6 x20.6mm Oven Controlled Crystal Oscillator

Feature

- Dimension 20.6 x 20.6 x 11.0 mm typical
- SC Cut crystal



Electrical Specifications

Parameter	Min.	Type	Max.	Unit	
OUTPUT (PIN = "R.F. OUTPUT")					
Frequency	5	10	40	MHz	
Output Level:					
HCMOS	Output High			V	
HCMOS	Output Low		0.5	V	
Waveform:	Rectangular				
Load	15				
Duty(Rectangular)	45	50	55	%	
Frequency stability					
Frequency stability	Ambient (0~70°C/ -30~+70°C /-40~+85°C)	±5,±10, ±20			ppb
	Daily	-0.5		+0.5	ppb
	Yearly	-50		+50	ppb
	10 Years	-0.3		+0.3	ppm
	Voltage(±5% change)	-0.5		+0.5	ppb
	Load(±5% change)	-0.5		+0.5	ppb
	Warm-up	-50		50	ppb
	Aging	-0.5		+0.5	ppb
Phase Noise	10Hz			-115	dBc/Hz
	100Hz			-135	
	1kHz			-145	
	10kHz			-150	
ELECTRICAL FREQUENCY ADJUSTMENT (PIN = "VCO INPUT")					
Tuning Range	VCO @ 0 V			-0.5	ppm
	VCO @ 4.0V	+0.5			ppm
Control Voltage	0	2	4.0	V	
INPUT POWER (PIN = "+VDC")					
Voltage	4.75	5.0	5.25	V	
Current			500	mA	
Steady State			1.0	W	
Reference Voltage					
Voltage	3.8	4.0	4.2	V	
Storage Temperature	-55		+125	°C	

Dimension(mm)

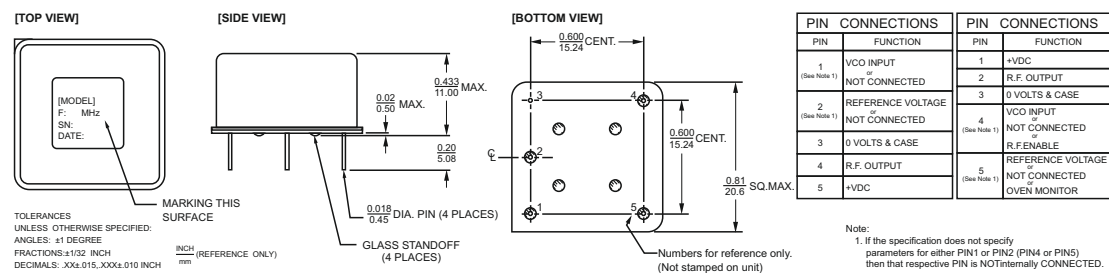

25.4 x22.1 mm Oven Controlled Crystal Oscillator

Feature

- Dimension 25.4 x 22.1 x 11.0 mm typical
- SC Cut crystal

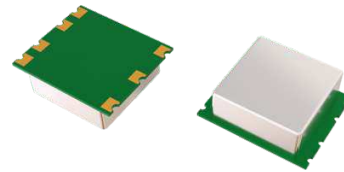

Electrical Specifications

Parameter	Min.	Type	Max.	Unit	
OUTPUT (PIN = "R.F. OUTPUT")					
Frequency	5	10	40	MHz	
Output Level:	Output High	2.4		V	
	Output Low		0.4	V	
Waveform:	Rectangular				
Load		15		pF	
Duty(Rectangular)	45	50	55	%	
Frequency stability					
Frequency stability	Ambient (0~70°C/ -30~+70°C /-40~+85°C)	±5,±10, ±20		ppb	
	Aging	-0.5		+0.5	ppb
	Daily	-0.5		+0.5	ppb
	Yearly	-50		+50	ppb
	10 Years	-0.4		+0.4	ppm
	Voltage(±5% change)	-0.5		+0.5	ppb
	Load(±5% change)	-0.5		+0.5	ppb
Phase Noise	Warm-up	-10		10	ppb
	10Hz			-115	dBc/Hz
	100Hz			-130	
	1kHz			-140	
10kHz			-150		
ELECTRICAL FREQUENCY ADJUSTMENT (PIN = "VCO INPUT")					
Tuning Range	VCO @ 0 V			-0.5	ppm
	VCO @ 2.8V	+0.5			ppm
Control Voltage	0	1.4	2.8	V	
INPUT POWER (PIN = "+VDC")					
Voltage	3.135	3.3	3.465	V	
Current			1000	mA	
Steady State			1.2	W	
Reference Voltage					
Voltage	2.7	2.8	2.9	V	
Storage Temperature	-55		+125	°C	

Dimension(mm)

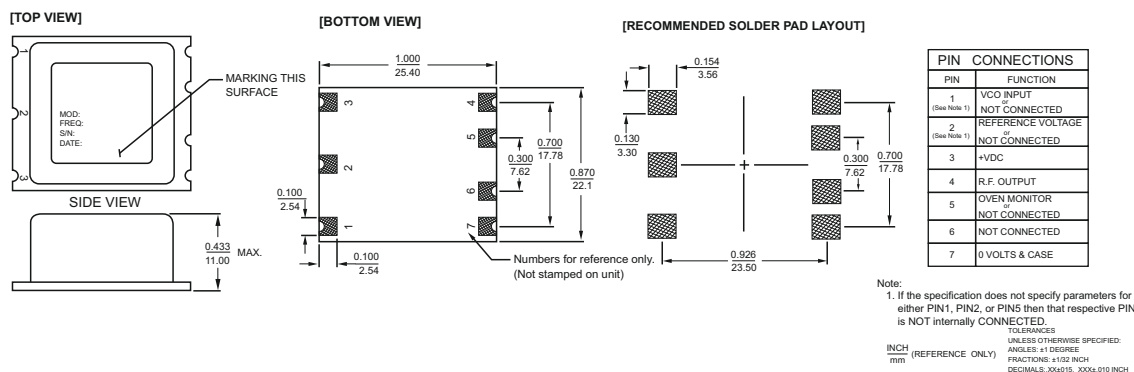

25.4 x25.4mm Oven Controlled Crystal Oscillator

Feature

- Typical 25.4 x25.4 x 12.7 mm
- Hermetically Sealed DIP Package
- Low power consumption and high reliability
- SC Cut Crystal



Electrical Specifications

Parameter		3.3V			5.0V			Unit
		Min.	Type	Max.	Min.	Type	Max.	
OUTPUT (PIN = "R.F. OUTPUT")								
Frequency		5		40	5		40	MHz
Output Level:	Output High	2.4			2.4			V
	Output Low			0.4			0.4	V
Waveform:		Rectangular			Rectangular			
Load			15			15		pF
Duty		45	50	55	45	50	55	%
Frequency stability								
Frequency stability	Ambient (0~+70°C/-30~+70°C /-40~+85°C)	±0.5, ±1, ±3, ±5, ±10			±0.5, ±1, ±3, ±5, ±10			ppb
	Daily	-0.5		+0.5	-0.5		+0.5	ppb
	Yearly	-50		+50	-50		+50	ppb
	10 Years	-0.3		+0.3	-0.3		+0.3	ppm
	Voltage(±5% change)	-0.5		+0.5	-0.5		+0.5	ppb
	Short term			0.05			0.05	ppb/s
	Load(±5% change)	-0.5		+0.5	-0.5		+0.5	ppb
	Warm-up	-10		+10	-10		+10	ppb
Phase Noise	1Hz		-95	-90		-95	-90	dBc/Hz
	10Hz		-125	-120		-125	-120	
	100Hz		-140	-135		-140	-135	
	1kHz		-148	-145		-148	-145	
	10kHz		-156	-155		-156	-155	
	100kHz		-158	-155		-158	-155	
ELECTRICAL FREQUENCY ADJUSTMENT (PIN = "VCO INPUT")								
Tuning Range	VCO @ Min. Voltage			-0.5			-0.5	ppm
	VCO @ Max. Voltage	+0.5			+0.5			ppm
Control Voltage	Ordering Information	0	+1.65	+3.3	0	+2.5	+5.0	V
		0	+1.4	+2.8	0	+2.0	+4.0	V
INPUT POWER (PIN = "+VDC")								
Voltage		+3.135	+3.3	+3.465	+4.75	+5.0	+5.25	V
Current				1000			800	mA
Steady State				1.3			1.3	W
REFERENCE VOLTAGE (PIN = "REFERENCE VOLTAGE")								
Voltage		+2.7	+2.8	+2.9	+3.8	+4.0	+4.2	V
Storage Temperature		-55		+125	-55		+125	°C

DIMENSION(mm)

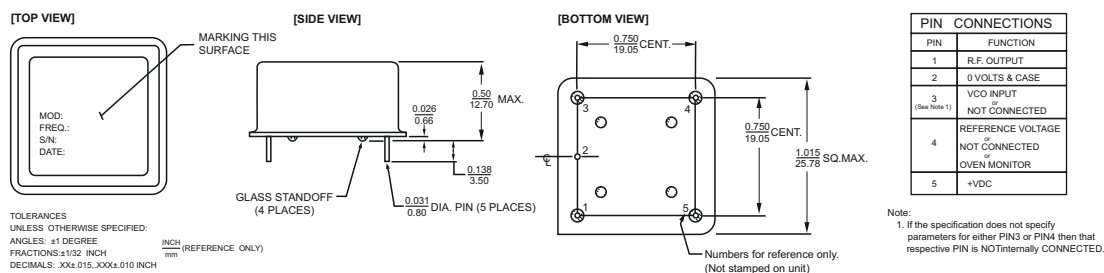

25.4x25.4 mm Oven Controlled Crystal Oscillator

Feature

- Typical 25.4 x25.4 mm.
- Low Phase Noise, Low G-Sensitivity
- Tight Frequency Stability
- Low Power Consumption, Fast Warm-up Time
- Electrical Frequency Tuning Input
- Reference Voltage Output



Electrical Specifications

Parameter	12V			5.0V			Unit	
	Min.	Type	Max.	Min.	Type	Max.		
OUTPUT (PIN = "R.F. OUTPUT")								
Frequency		10			100		MHz	
Initial Accuracy	-0.1		+0.1	-0.3		+0.3	ppm	
Waveform:	Sine Wave			Rectangular				
Frequency stability								
Frequency stability	Ambient (-20~+70°C / -40~+85°C)	± 5, ±10, ±20, ±30, ±50, ±100			± 20, ±50, ±100			ppb
	Daily	-0.5		+0.5	-5		+5	ppb
	Yearly	-50		+50	-500		+500	ppb
	10 Years	-0.3		+0.3	-2		+2	ppm
	Voltage(±5% change)	-1.0		+1.0	-5		+5	ppb
	Short term			0.002			0.05	ppb/s
	Load(±5% change)	-1.0		+1.0	-5		+5	ppb
Warm-up	-50		+50	-50		+50	ppb	
G-Sensitivity(each axis)			-			1	Ppb/g	
Phase Noise	10Hz		-140	-142		-97	-100	dBc/Hz
	100Hz		-155	-155		-130	-135	
	1kHz		-165	-165		-160	-162	
	10kHz		-170	-170		-173	-170	
	100kHz		-170	-170		-175	-172	
	1MHz		-170	-170		-178	-175	
ELECTRICAL FREQUENCY ADJUSTMENT (PIN = "VCO INPUT")								
Tuning Range	VCO @ Min. Voltage	± 0.4			± 3		ppm	
Control Voltage	Ordering Information	0.5	5.0	+9.5	0	5.0	+10.0	V
INPUT POWER (PIN = "+VDC")								
Voltage		+11.4	+12	+12.6	+11.4	+12	+12.6	V
Current				500			380	mA
Steady State				2.0			2.0	W
REFERENCE VOLTAGE (PIN = "REFERENCE VOLTAGE")								
Voltage		+9.25	+9.5	+9.75	+9.5	+10	+10.5	V
Storage Temperature		-55		+125	-55		+125	°C

Dimension(mm)

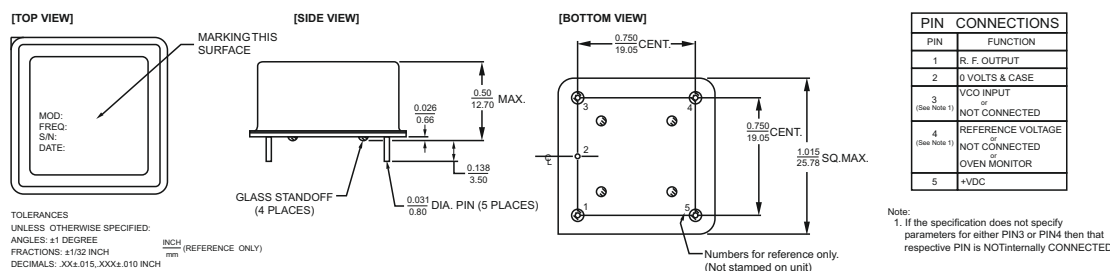

36.3x27.2mm Oven Controlled Crystal Oscillator

FEATURE

- Typical 36.3 x 27.2 x 12.7 mm.
- SC Cut crystal



Electrical Specifications

Parameter		12V			5.0V			Unit
		Min.	Type	Max.	Min.	Type	Max.	
OUTPUT (PIN = "R.F. OUTPUT")								
Frequency		5	10	40	5	10	40	MHz
Output Level:	Output High	2.6			2.4			V
	LVTTTL Output Low			0.4			0.4	V
Waveform:		Rectangular			Rectangular			
Load			15			15		pF
Duty		45	50	55	45	50	55	%
Frequency stability								
Frequency stability	Ambient (0~70°C / -30~+70°C / -40~+85°C)	±3, ±5, ±10			±3, ±5, ±10			ppb
	Aging	-0.5		+0.5	-0.5		+0.5	ppb
	Daily	-0.5		+0.5	-0.5		+0.5	ppb
	Yearly	-50		+50	-50		+50	ppb
	10 Years	-0.3		+0.3	-0.3		+0.3	ppm
	Voltage(±5% change)	-0.5		+0.5	-0.5		+0.5	ppb
	Load(±5% change)	-0.5		+0.5	-0.5		+0.5	ppb
Warm-up	-10		+10	-10		+10	ppb	
Phase Noise	10Hz		-125	-120		-125	-120	dBc/Hz
	100Hz		-140	-135		-140	-135	
	1kHz		-148	-145		-148	-145	
	10kHz		-156	-155		-156	-155	
ELECTRICAL FREQUENCY ADJUSTMENT (PIN = "VCO INPUT")								
Tuning Range	VCO @ Min. Voltage			-0.5			-0.5	ppm
	VCO @ Max. Voltage	+0.5			+0.5			ppm
Control Voltage	Ordering Information	0	+2.5	+5.0	0	+2.5	+5.0	V
		0	+2.0	+4.0	0	+2.0	+4.0	V
INPUT POWER (PIN = "+VDC")								
Voltage		+11.4	+12	+12.6	+4.75	+5.0	+5.25	V
Current				1000			850	mA
Steady State				1.3			1.3	W
REFERENCE VOLTAGE (PIN = "REFERENCE VOLTAGE")								
Voltage		+4.75	+5.0	+5.25	+3.8	+4.0	+4.2	V
Storage Temperature		-55		+125	-55		+125	°C

Dimension(mm)

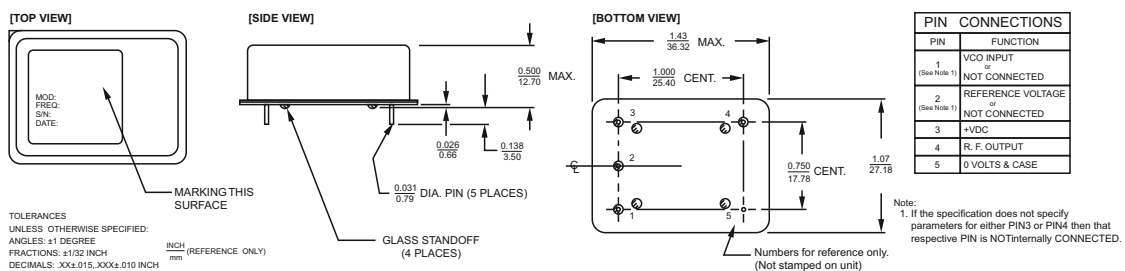

36.3 x27.2mm Double Oven Controlled Crystal Oscillator

Feature

- Typical 36.3 x27.2 x 18.7mm.
- Hermetically Sealed Package
- Low power consumption and high reliability



Electrical Specifications

Parameter	3.3V			5.0V			Unit	
	Min.	Type	Max.	Min.	Type	Max.		
OUTPUT (PIN = "R.F. OUTPUT")								
Frequency		10			10		MHz	
Initial Accuracy	-0.1		+0.1	-0.1		+0.1	ppm	
Output Level:	Output High	2.4		4.4			V	
	Output Low		0.3			0.3	V	
Waveform:	Rectangular			Rectangular				
Frequency stability								
Frequency stability	Ambient (0~+70°C / -30~+70°C)	±0.2, ±0.5		±0.2, ±0.5			ppb	
	Daily	±0.1, ±0.3		±0.1, ±0.3			ppb	
	Yearly	±20, ±50		±20, ±50			ppb	
	10 Years	±0.1, ±0.2		±0.1, ±0.2			ppm	
	Voltage(±5% change)	-0.2		+0.2	-0.2		+0.2	ppb
	Short term			0.007			0.007	ppb/s
	Load(±5% change)	-0.2		+0.2	-0.2		+0.2	ppb
Warm-up	-20		+20	-20		+20	ppb	
Phase Noise	10Hz					-120	dBc/Hz	
	100Hz					-138		
	1kHz					-148		
	10kHz					-155		
	100kHz					-158		
ELECTRICAL FREQUENCY ADJUSTMENT (PIN = "VCO INPUT")								
Tuning Range	VCO @ Min. Voltage	-0.8		-0.35	-0.8		-0.35	ppm
	VCO @ Max. Voltage	+0.35		+0.8	+0.35		+0.8	ppm
Control Voltage	Ordering Information	0	+1.4	+2.8	0	+1.4	+2.8	V
INPUT POWER (PIN = "+VDC")								
Voltage	+3.135	+3.3	+3.465	+4.75	+5.0	+5.25	V	
Current			2.5			1.75	A	
Steady State			2.5			2.5	W	
REFERENCE VOLTAGE (PIN = "REFERENCE VOLTAGE")								
Voltage	+2.66	+2.8	+2.94	+3.8	+4.0	+4.2	V	
Storage Temperature	-40		+85	-40		+85	°C	

Dimension(mm)

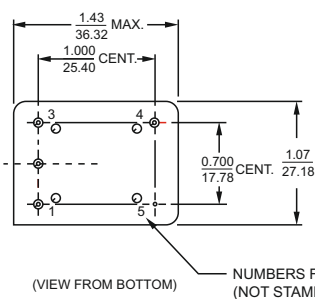
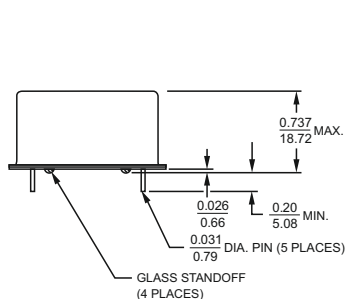

PIN CONNECTIONS	
PIN	FUNCTION
1 (See Note 1)	VCO INPUT OR NOT CONNECTED
2 (See Note 1)	REFERENCE VOLTAGE OR OVEN MONITOR OR NOT CONNECTED
3	+VDC
4	R. F. OUTPUT
5	0 VOLTS & CASE

Note 1. If the specification does not specify parameters for either PIN1 or PIN2 then that respective PIN is NOT internally CONNECTED.

2.0x1.6 mm SMD SAW Resonator

Feature

- Small size 2.0x1.6x1.0mm
- The optional frequency can be customized
- High transmit and receive sensitivity
- High temperature resistance and impact resistance
- Good power and reliability
- RoHS compliant

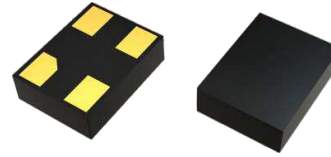

Electrical Specifications

Item			Minimum	Typical	Maximum	Unit
Frequency Range		f_c	154~1000MHz			MHz
Standard Frequency		f_c	303,315,390,433.92,435,72			MHz
Frequency Tolerance(at 25°C)		Δf_c	$\pm 50, \pm 75, \pm 150$ or specify			kHz
Insertion Loss (in 50ohm system, min)		IL	1.0,1.3,1.4, 1.5 or specify			dB
Temperature Stability	Turnover Temperature	T_0	25	40	55	°C
	Turnover Frequency	f_0		f_c		
	Frequency Temperature Coefficient	FTC		0.037		ppm/°C
Frequency Aging	Absolute Value during the First Year	$ f_A $		≤ 10		ppm/yr
DC Insulation Resistance between Any Two Pins			1.0			MΩ
Operating Temperature Range			-40~+85			°C
Storage Temperature Range			-40~+85			°C

Dimension(mm)

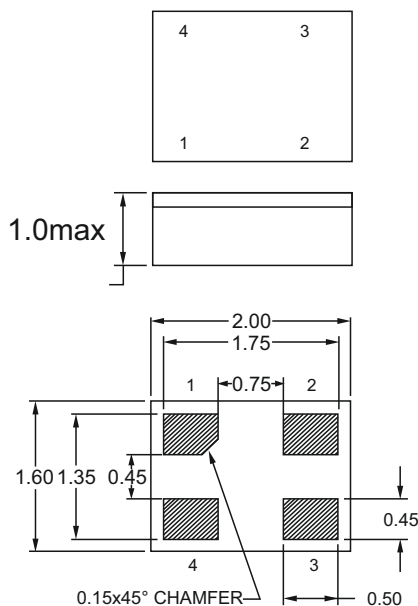

Pin No.	Description
1	Input/ Output
3	Output/ Input
2,4	Ground

3.0x3.0 mm SMD SAW Resonator

Feature

- Small size 3.0x3.0x1.3mm
- The optional frequency can be customized
- High transmit and receive sensitivity
- High temperature resistance and impact resistance
- Good power and reliability
- RoHS compliant

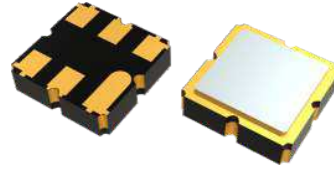

Electrical Specifications

Item		Minimum	Typical	Maximum	Unit	
Frequency Range		154~1000MHz			MHz	
Standard Frequency		315,330, 370,433.92,868,915			MHz	
Frequency Tolerance(at 25°C)		±50, ±75, ±150 or specify			KHz	
Insertion Loss (in 50ohm system, min)		1.0,1.3,1.4, 1.5 or specify			dB	
Temperature Stability	Turnover Temperature	T ₀	25	40	55	°C
	Turnover Frequency	f ₀		f _c		
	Frequency Temperature Coefficient	FTC		0.032		ppm/°C
Frequency Aging	Absolute Value during the First Year	f _Δ		≤10		ppm/yr
DC Insulation Resistance between Any Two Pins			1.0			MΩ
Operating Temperature Range		-40~+85			°C	
Storage Temperature Range		-55~+125			°C	

Dimension(mm)

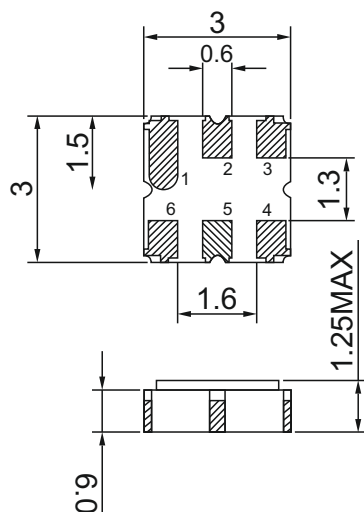

Pin No.	Description
2	Input/Output
5	Output/Input
1,3,4,6	Case Ground

3.8x3.8 mm SMD SAW Resonator

Feature

- Small size 3.8x3.8x1.5 mm
- The optional frequency can be customized
- High transmit and receive sensitivity
- High temperature resistance and impact resistance
- Good power and reliability
- RoHS compliant

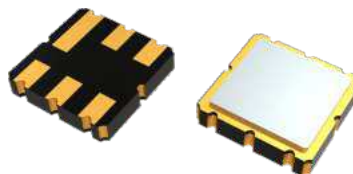

Electrical Specifications

Item		Minimum	Typical	Maximum	Unit	
Frequency Range		154~1000MHz			MHz	
Standard Frequency		315,330, 370,433.92,868,915			MHz	
Frequency Tolerance(at 25°C)		±50, ±75, ±150 or specify			KHz	
Insertion Loss (in 50ohm system, min)		1.0,1.3,1.4, 1.5 or specify			dB	
Temperature Stability	Turnover Temperature	T ₀	25	40	55	°C
	Turnover Frequency	f ₀		f _c		
	Frequency Temperature Coefficient	FTC		0.032		ppm/°C
Frequency Aging	Absolute Value during the First Year	f _Δ		≤10		ppm/yr
DC Insulation Resistance between Any Two Pins		1.0				MΩ
Operating Temperature Range		-40~+85			°C	
Storage Temperature Range		-55~+125			°C	

Dimension(mm)

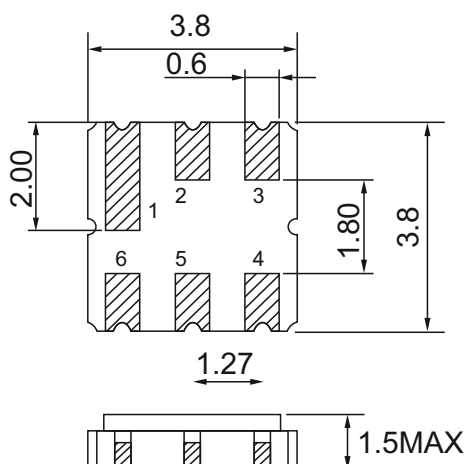

Pin No.	Description
2	Input/Output
5	Output/Input
1,3,4,6	Case Ground

5.0×5.0 mm SMD SAW Resonator

Feature

- Size 5.0x5.0x1.5 mm
- The optional frequency can be customized
- High transmit and receive sensitivity
- High temperature resistance and impact resistance
- Good power and reliability
- RoHS compliant

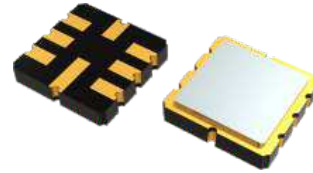

Electrical Specifications

Item		Minimum	Typical	Maximum	Unit	
Frequency Range		154~1000MHz			MHz	
Standard Frequency		315,330, 370,433.92,868,915			MHz	
Frequency Tolerance(at 25°C)		Δf_c ±50, ±75, ±150 or specify			KHz	
Insertion Loss (min)		1.0,1.3,1.4, 1.5 or specify			dB	
Temperature Stability	Turnover Temperature	T_0	25	40	55	°C
	Turnover Frequency	f_0		f_c		
	Frequency Temperature Coefficient	FTC		0.032		ppm/°C
Frequency Aging	Absolute Value during the First Year	$ f_A $		≤10		ppm/yr
DC Insulation Resistance between Any Two Pins		1.0				MΩ
Operating Temperature Range		-40~+85			°C	
Storage Temperature Range		-55~+125			°C	

Dimension(mm)

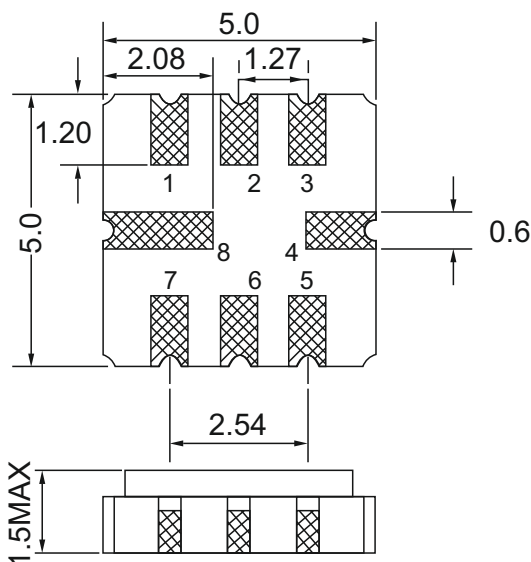

Pin No.	Description
2	Input/Output
6	Output/Input
1,3,5,7	To be grounded
4,8	Case Ground

5.0x3.5 mm SMD SAW Resonator

Feature

- Size 5.0x3.5x1.5 mm
- The optional frequency can be customized
- High transmit and receive sensitivity
- High temperature resistance and impact resistance
- Good power and reliability
- RoHS compliant

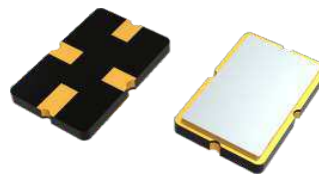

Electrical Specifications

Item		Minimum	Typical	Maximum	Unit	
Frequency Range		154~1000MHz			MHz	
Standard Frequency		315,330, 370,433.92,868,915			MHz	
Frequency Tolerance(at 25°C)		Δf_c $\pm 50, \pm 75, \pm 150$ or specify			KHz	
Insertion Loss (min)		1.0,1.3,1.4, 1.5 or specify			dB	
Temperature Stability	Turnover Temperature	T_0	25	40	55	°C
	Turnover Frequency	f_0		f_c		
	Frequency Temperature Coefficient	FTC		0.032		ppm/°C
Frequency Aging	Absolute Value during the First Year	$ f_A $		≤ 10		ppm/yr
DC Insulation Resistance between Any Two Pins			1.0			M Ω
Operating Temperature Range					-40~+85	°C
Storage Temperature Range					-55~+125	°C

Dimension(mm)

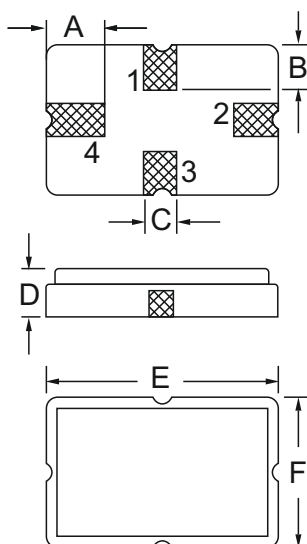

Sign	Data (unit: mm)	Sign	Data (unit: mm)
A	1.2±0.1	D	1.4±0.1
B	0.8±0.1	E	5.0±0.1
C	0.5	F	3.5±0.1

Pin No.	Description
1	Input/Output
3	Output/Input
2,4	Case Ground

1.1x0.9 mm SMD SAW Filter

Feature

- Small size 1.1x 0.9, Ultra thin , thickness 0.5mm
- CSP process with chip scale package
- Standardization of small size
- Good stability and high reliability
- Mainly used in GPS navigation
- TDD/FDD communication and artificial intelligence chips
- RoHS compliant

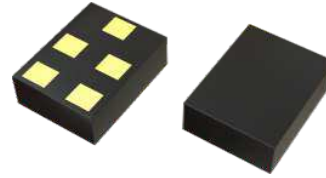

Electrical Specifications

Item		Specifications	Unit
Frequency Range	f_c	800~2605MHz	MHz
Standard Frequency		1575.42, 1582.4, 1568	MHz
Useful Band Width		3,18,48 or specify	MHz
Insertion Loss (min)	IL	0.9,1.3,1.8, 2.2 or specify	dB
VSWR(max)		2.0	dB
Operating emperature Range		-40~+85	°C
Storage Temperature Range		-40~+85	°C

Dimension(mm)

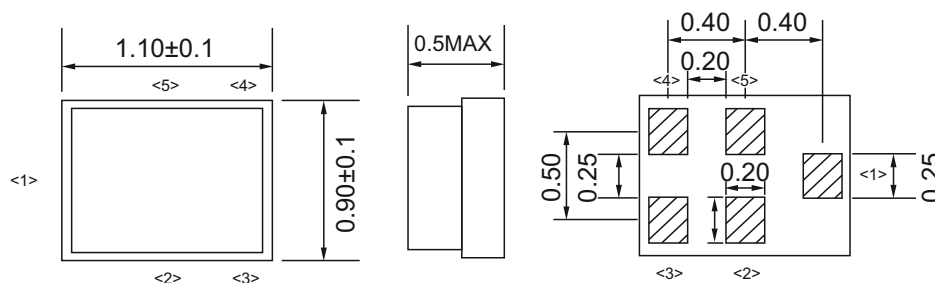

Pin No.	Description
1	Input
4	Output
2,3,5	To be grounded

1.4x1.1 mm SMD SAW Filter

Feature

- Small size 1.4x 1.1
- CSP process with chip scale package
- Standardization of small size
- Good stability and high reliability
- Mainly used in GPS navigation
- TDD/FDD communication and artificial intelligence chips
- RoHS compliant

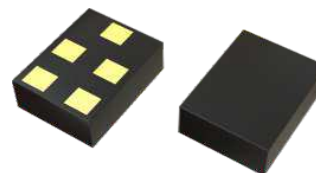

Electrical Specifications

Item		Specifications	Unit
Frequency Range	f _c	800~2605MHz	MHz
Standard Frequency		868.5,1575.42, 1582.4,1568	MHz
Useful Band Width		3,18,48 or specify	MHz
Insertion Loss (min)	IL	0.9,1.3,1.8, 2.2 or specify	dB
VSWR(max)		2.0	dB
Operating emperature Range		-40~+85	°C
Storage Temperature Range		-40~+85	°C

Dimension(mm)

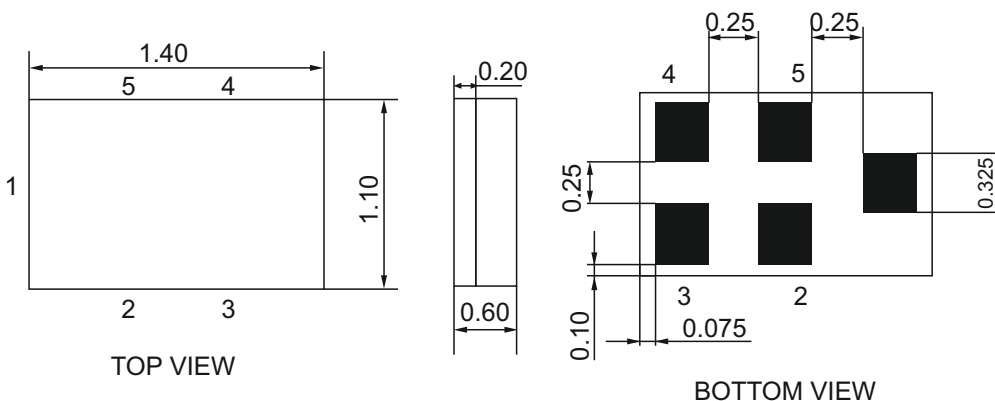

Pin No.	Description
1	Input
4	Output
2,3,5	To be grounded

2.0X1.5 mm SMD SAW Filter

Feature

- Small size 2.0x1.5x0.6mm
- CSP process with chip scale package
- Standardization of small size
- Good stability and high reliability
- Mainly used in GPS navigation
- TDD/FDD communication and artificial intelligence chips
- RoHS compliant

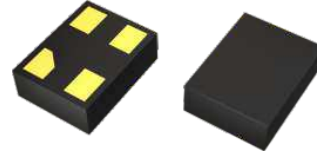

Electrical Specifications

Item		Specifications	Unit
Frequency Range	f_c	800~2605MHz	MHz
Standard Frequency		861,915, 921.5,2345	MHz
Useful Band Width		5,25,40,50 or specify	MHz
Insertion Loss (min)	IL	1.5,2.5,3.2 or specify	dB
Operating emperature Range		-40~+85	°C
Storage Temperature Range		-40~+85	°C

Dimension(mm)

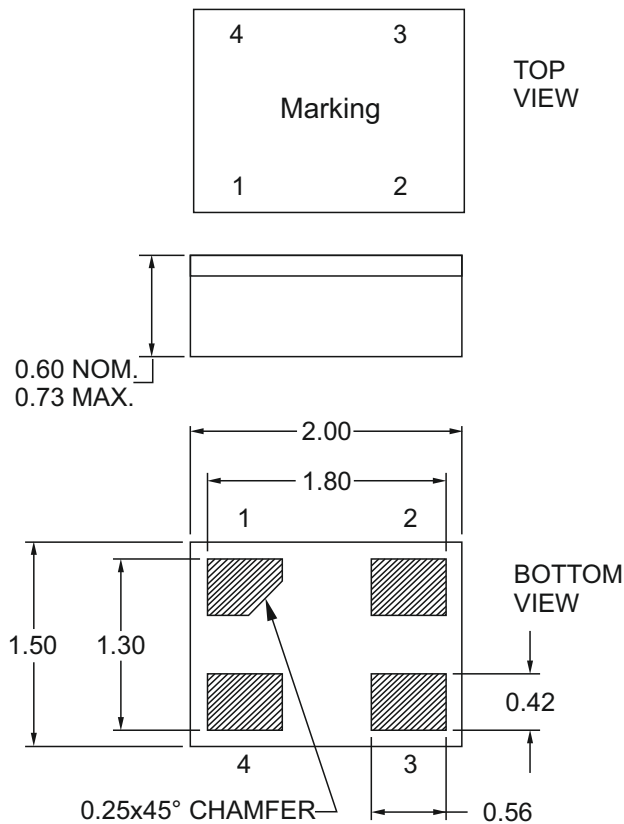

Pin No.	Description
1	Input
3	Output
2,4	Case Ground

3.0X3.0 mm SMD SAW Filter

Feature

- Small size 3.0x3.0x1.25mm
- Welding can be done with automatic mounting
- Low-loss SAW component
- Low amplitude ripple
- Sharp rejections at both out-bands
- RoHS Compliant

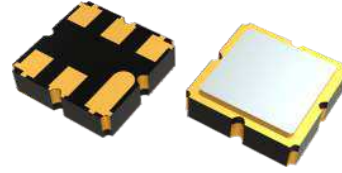

Electrical Specifications

Item		Specificaations	Unit
Frequency Range	f_c	300~2605MHz	MHz
Standard Frequency	f_c	433.92,861,915,1575.42,1582.4,2492 Band1,2,3,5,6,8,12,13,16,17,20,27,28,34,38,39,40,41	MHz
Band Width		6, 10, 15,50 or specify	MHz
Insertion Loss (min)	IL	1.0,1.5,3.0, 6.5 or specify	dB
Operating emperature Range		-40~+85	°C
Storage Temperature Range		-55~+125	°C

Dimension(mm)

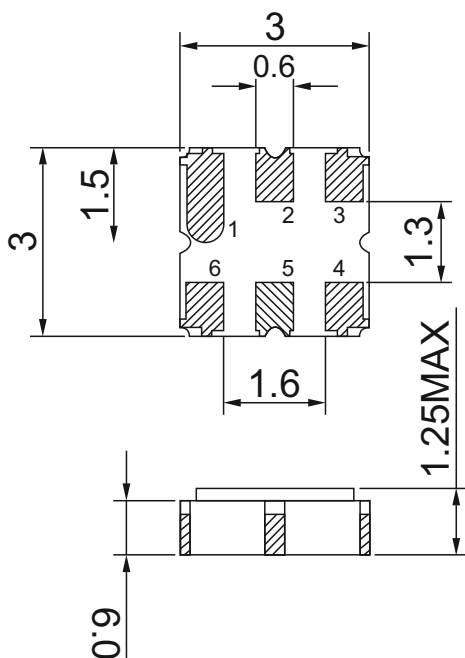

Pin No.	Description
2	Input
5	Output
1,3,4,6	Ground

3.8×3.8 mm SMD SAW Filter

Feature

- Small size 3.8x3.8x1.5mm
- Welding can be done with automatic mounting
- Low-loss SAW component
- Low amplitude ripple
- Sharp rejections at both out-bands
- RoHS Compliant

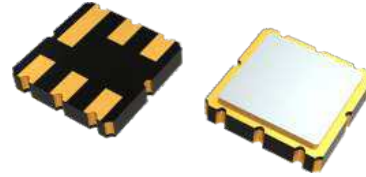

Electrical Specifications

Item		Specificaations	Unit
Frequency Range	f_c	100~1000MHz	MHz
Standard Frequency	f_c	315,433.92,480,500,866.5	MHz
Band Width		2, 3,5,10,20,40, or specify	MHz
Insertion Loss (min)		1.5,1.8,2.0,3.0, 6.5 or specify	dB
Operating emperature Range	IL	-40~+85	°C
Storage Temperature Range		-55~+125	°C

Dimension(mm)

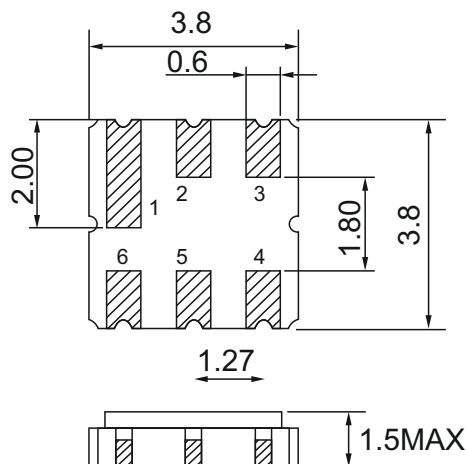

Pin No.	Description
2	Input/Output
5	Output/Input
1,3,4,6	Case Ground

5.0×5.0 mm SMD SAW Filter

Feature

- Small size 5.0x5.0x1.5mm
- Welding can be done with automatic mounting
- Low-loss SAW component
- Low amplitude ripple
- Sharp rejections at both out-bands
- RoHS Compliant

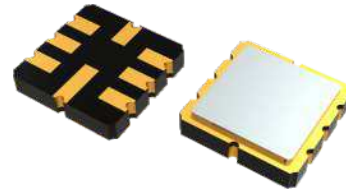

Electrical Specifications

Item		Specifications	Unit
Frequency Range	f_c	100~1000MHz	MHz
Standard Frequency	f_c	110,315,433.92	MHz
Band Width		2, 3,5, 10, 20 or specify	MHz
Insertion Loss (min)		1.8,2.2,3.0, 6.5 or specify	dB
Operating emperature Range	IL	-40~+85	°C
Storage Temperature Range		-55~+125	°C

Dimension(mm)

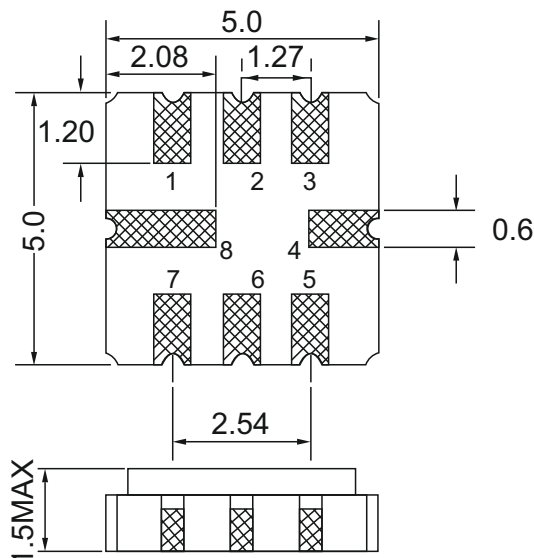

2	Input/Output
6	Output/Input
1,3,5,7	To be grounded
4,8	Case Ground

Aldinet



Quartz Crystal
Always WTL

WTL International Limited

Quartz Crystal
Tuning Fork Crystal
Crystal Oscillator
VCTCXO, TCXO
VCXO
OCXO
Saw Device



WTL International Limited

Address: Room 203, Unit A, Block 7, D&J Innovation Park Phase 2,
No.73 Xiali South Road, Longgang District, 518114, Shenzhen, China

Phone : +86-755-82677582

Email : wtl@wtlcrystals.com

Web : www.wtlcrystals.com

1688: wtlcrystals.1688.com

